



NOTES:

1. SYMBOL  INDICATES MOUNTING POINT, 3/8-16THREADED HOLE (PI ANGLE).
2. SYMBOL  INDICATES MOUNTING POINT, 3/8-16THREADED HOLE (NUT PLATE).
3. SYMBOL  INDICATES CENTER OF BALANCE.
4. WEIGHT APPROX. 56 LBS.
5. SHIPPING WEIGHT APPROX. 64 LBS.

REV	DESCRIPTION	APVD/DATE
A	NEW ISSUE PER DSRWHT6963 KL 1/16/05	RS 1-23-06

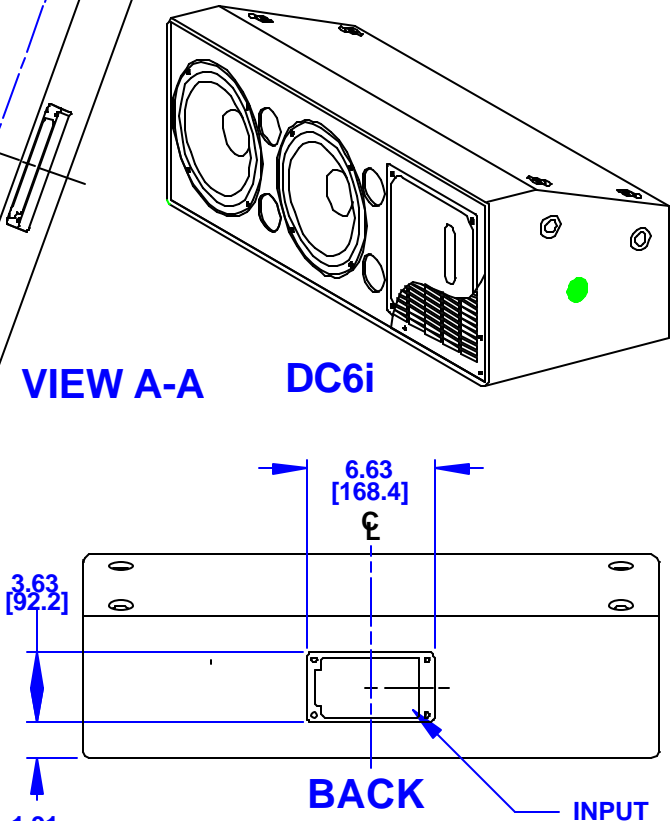
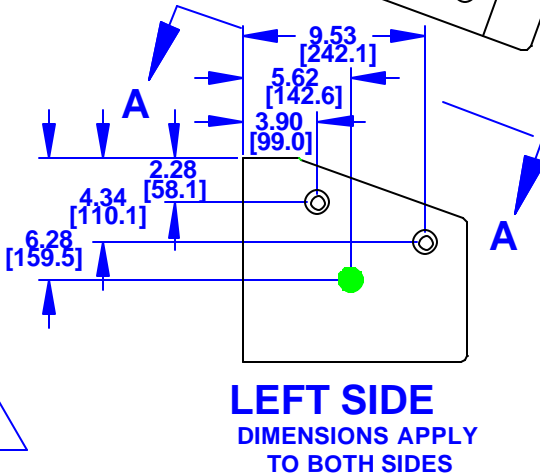
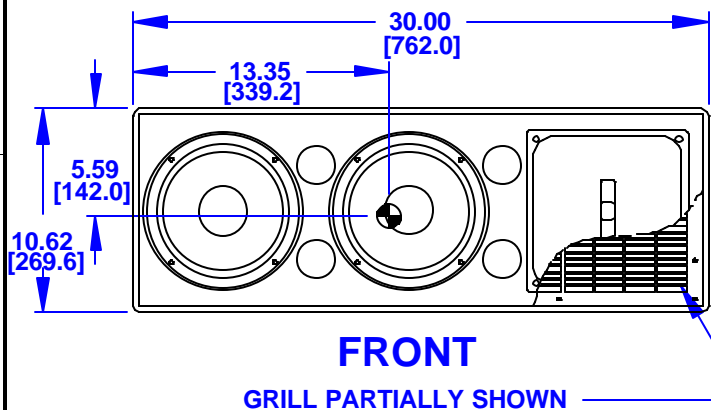
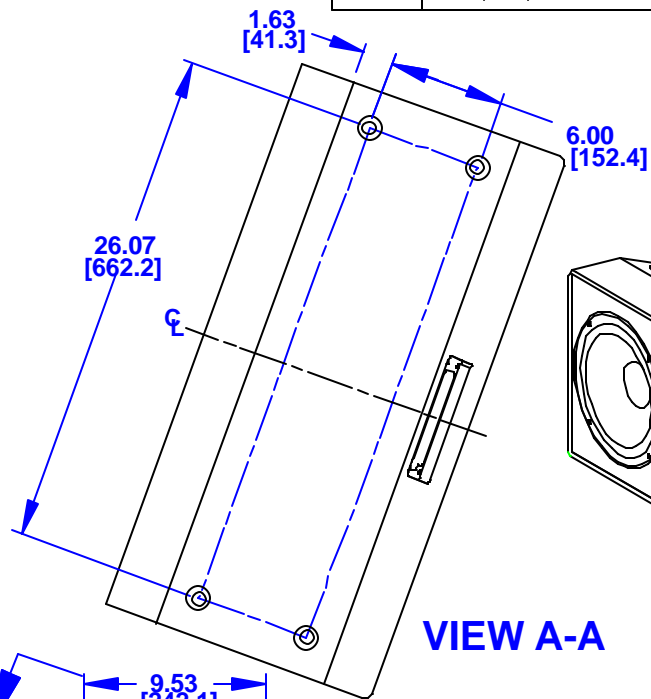
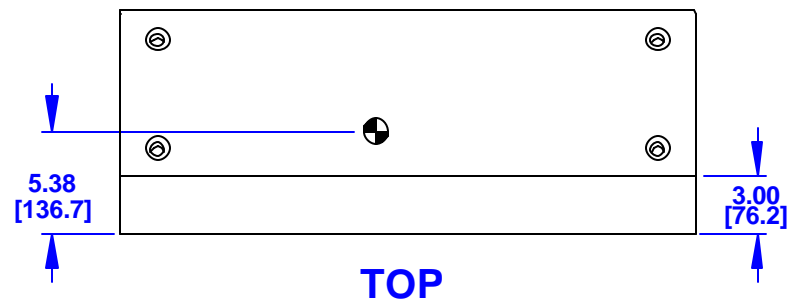

DOCUMENT CONTROL PER SPECIFICATION 4.5.201

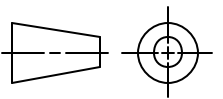
<p>THIRD ANGLE PROJECTION</p> 	<p>UNLESS OTHERWISE SPECIFIED: ALL DIMENSIONS ARE IN INCHES DUAL [MM] DIMENSIONS REF ONLY</p> <p>TOLERANCE IN INCHES .X ±.03 .XX ±.015 .XXX ±.005 FRACTIONS ±1/32 ANGLES ±1/2°</p> <p>(X.XX) - REF DIMS NO TOLERANCE IMPLIED</p> <p>TSC—THEORETICAL SHARP CORNER DIMENSIONS ACROSS CENTERLINES TO BE SYMMETRICAL</p>	<p>STATUS: PRODUCTION</p>		<p>EA EASTERN ACOUSTIC WORKS ONE MAIN STREET WHITINSVILLE, MA 01588 USA</p>	
		<p>APPROVALS</p> <p>DRAWN: CA</p> <p>CHECKED: KFH</p> <p>DES ENG: ZC</p> <p>MFG ENG: SM</p>	<p>DATE</p> <p>1/11/06</p> <p>1/24/06</p> <p>1/26/06</p> <p>1/25/06</p>		<p>TITLE: CABINET/FINISHED/BLACK/DC6i [MECHANICAL SPECIFICATION]</p>
<p>THIS DRAWING IS THE PROPERTY OF EA AND SHALL NOT BE COPIED, REPRODUCED, OR USED AS THE BASIS FOR MANUFACTURE OR SALE OF APPARATUS WITHOUT WRITTEN AUTHORIZATION. DO NOT SCALE DRAWING.</p>		<p>A SHEET 1 OF 1</p>	<p>SCALE: 1 TO 10</p>	<p>DRAWING NUMBER: 0012495</p>	<p>REVISION: A</p>