

NOTES:
 1. REFER TO EAW MATERIAL SPEC. 480455 FOR LABELING AND SHIPPING REQUIREMENTS.

REV	DESCRIPTION	APVD/DATE
A	NEW ISSUE PER DSR 02-121 PSN 1/29/02	RS 2/20/02

- 16X 102039 1/4-20 X 3/4" PH PHMS 18-8 BLK
- 18X 105008 1/4" SPLIT LOCK WASHER 18-8 BLK
- 18X 105007 1/4" FLAT WASHER 18-8 BLK
- 4X 150001 BLUE SWIVEL CASTER
- 2X 101047 CASTER PALLET MAGNET
- 2X 104004 1/4-20 X 3/4 JOINT CONNECTOR BOLT

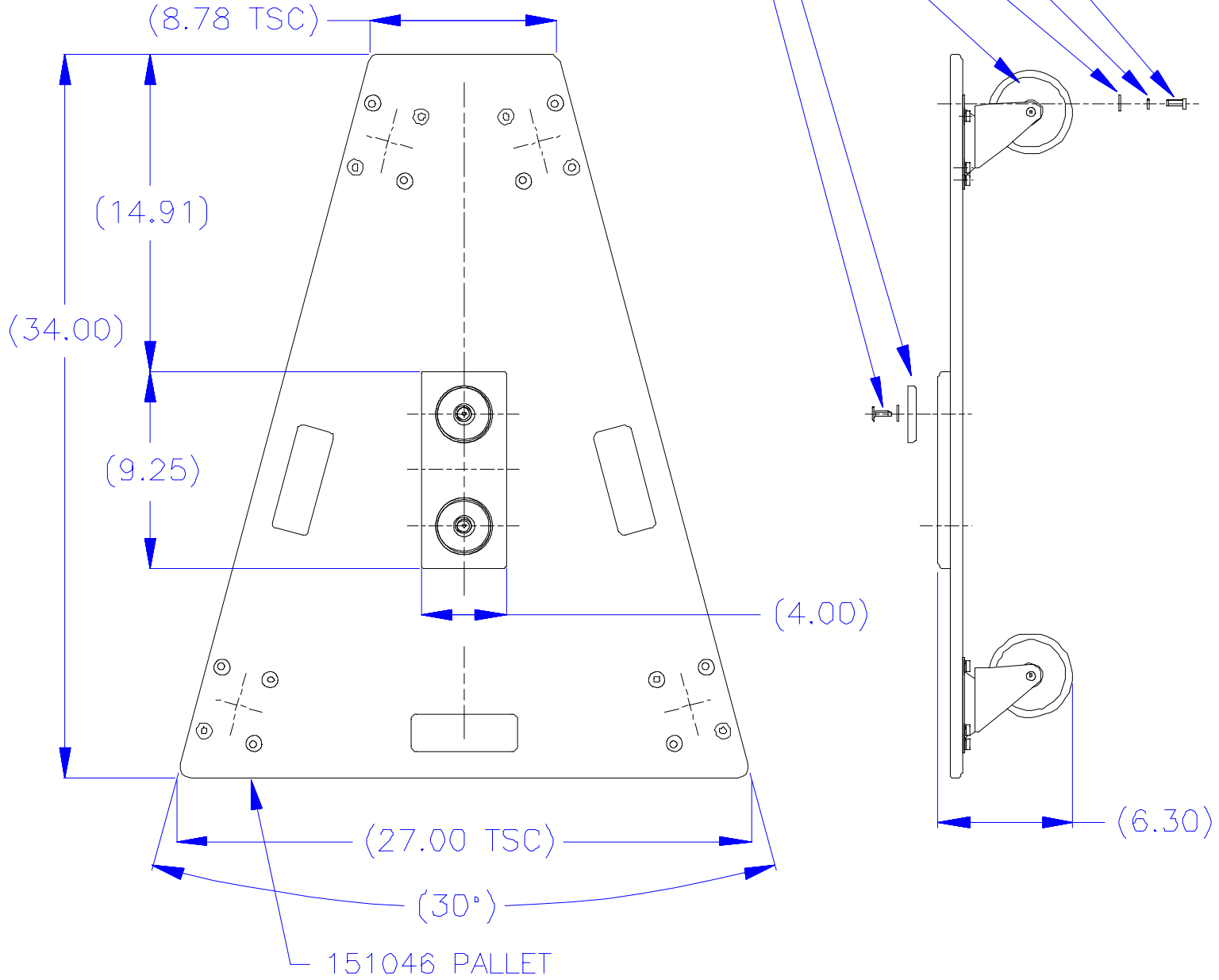

DOCUMENT CONTROL PER SPECIFICATION 4.5.201

THIRD ANGLE PROJECTION 	UNLESS OTHERWISE SPECIFIED: ALL DIMENSIONS ARE IN INCHES TOLERANCE IN INCHES .X ± .1 .XX ± .03 .XXX ± .010 FRACTIONS ±1/32 ANGLES ±1/2° (X.XX) = REF DIMS NO TOLERANCE IMPLIED T.S.C.=THEORETICAL SHARP CORNER DIMENSIONS ACROSS CENTERLINES TO BE SYMMETRICAL	STATUS: PRODUCTION		EASTERN ACOUSTIC WORKS ONE MAIN STREET WHITINSVILLE, MA 01588 USA			
		APPROVALS DRAWN: PSN CHECKED: RS DES ENG: JR MFG ENG: DD	DATE 1/29/02 2/20/02 2/22/02 2/25/02		TITLE: ASSEMBLY/CASTER PALLET [KF700]		
THIS DRAWING IS THE PROPERTY OF EAW AND SHALL NOT BE COPIED, REPRODUCED, OR USED AS THE BASIS FOR MANUFACTURE OR SALE OF APPARATUS WITHOUT WRITTEN AUTHORIZATION. DO NOT SCALE DRAWING.			A	SHEET 1 OF 1	SCALE: 1 TO 8	DRAWING NUMBER: 255049	REVISION A

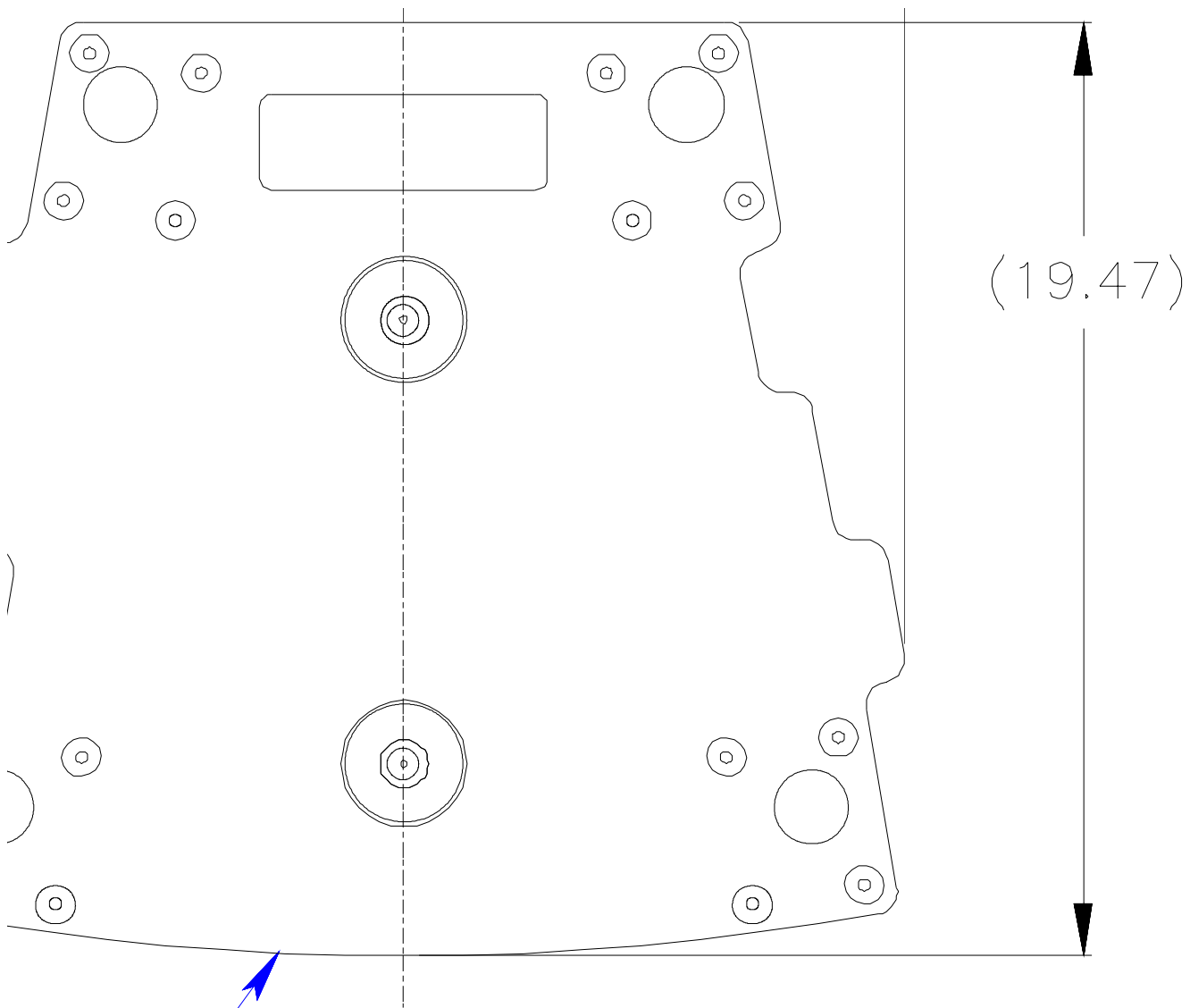

_LET

2X 104004 1/4 - 20 X 3/4
JOINT CONNECTOR BOLT

2X 101047 CASTER PALLET MAGN

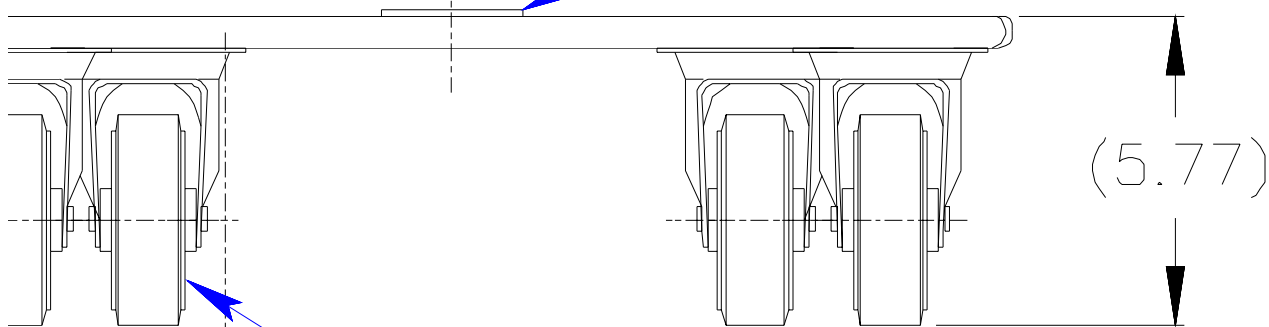

4X 150001 BLUE SWIVEL CASTER

18X 105007 1/4" FLAT WASHER 18-8 E

18X 105008 1/4" SPLIT LOCK WASHER

16X 102039 1/4-20 X 3/4 PH PHMS

DOCUMENT CONTROL PER SP