



SPECIFICATIONS L8CX2X0

FEATURES

- High performance ceiling-mount system
- 8-in LF/.75 dome tweeter (coaxially mounted)
- Internal passive crossover/filter network
- Optional 70 volt transformer available

DESCRIPTION

A 2-way passive full range coaxial ceiling system. Includes an 8-in woofer and a .75-in dome tweeter.

APPLICATIONS

The L8CX2X0 provides exceptionally flat response in a compact, ceiling mount coaxial system. Six year warranty.

Applications include:

- Boardrooms
- Transportation Centers
- Major Malls
- Large Retail
- Small Retail



PERFORMANCE

Note Data indicate performance of baffle-mounted system in tuned enclosure.

Frequency Response (1 Watt @ 1m)

±3 db 40 Hz to 20 kHz

Axial Sensitivity (dB SPL, 1 Watt @ 1m)

Full Range 90

Impedance (Ohms)

Full Range 8

Power Handling, AES Standard (Watts)

Full Range 70

Calculated Maximum Output (dB SPL @ 1m)

Full Range Peak 114.5

Full Range Long Term 108.5

Nominal Coverage Angle, -6 dB Points (degrees)

Conical 100

Recommended High-Pass Frequency

24 dB/Octave 50 Hz

PHYSICAL

LF Subsystem	1x 8-in Cone
HF Subsystem	1x .75-in soft dome tweeter
Configuration	2-way, full range
Powering	Passive
Options	70 volt transformer

Dimensions

	Inches	Millimeters
Height	7.12	181
Width	8.5	216
Depth	6	152

Weights

	Pounds	Kilograms
Net Weight	6	2.7
Shipping Weight	11	5.0





SPECIFICATIONS L8CX2X0

DIMENSIONAL DRAWING

L8CX2X0 ALL DIMENSIONS IN INCHES UNLESS OTHERWISE STATED.

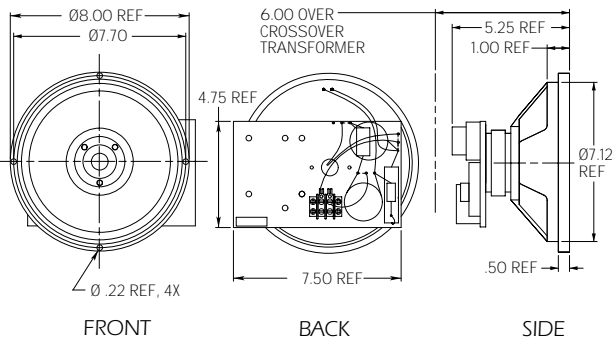

225112
EXP 3/22/97 SHB

A & E SPECIFICATIONS

The two-way coaxial full range loudspeaker systems shall incorporate an 8-in LF transducer and a .75-in dome tweeter HF transducer.

The HF driver shall be coaxially mounted within the LF cone. An internal passive filter network shall provide fourth order acoustical crossover and system equalization.

Frequency response of the baffle-mounted system in a tuned enclosure shall vary no more than ± 3 dB from 40 Hz to 20 kHz measured on axis. The loudspeaker shall produce a Sound Pressure Level (SPL) of 90 dB SPL on axis at 1 meter with a power input of 1 Watt, and shall be capable of producing a peak output of 114.5 SPL on axis at 1 meter. The loudspeaker shall handle 70 Watts of amplifier power (AES Standard) and shall have a nominal impedance of 8 Ohms.

The two-way coaxial full range loudspeaker shall be the EAW model L8CX2X0.