

NOTES:
 1. MATERIAL: 15mm INTERIOR GRADE LAMINATED BIRCH PLYWOOD—STANDARD HARDWARE.
 2. ROUT ALL OUTSIDE EDGES TO .50.

REV	DESCRIPTION	APVD/DATE
0	REVISED AND RELEASED TO PRODUCTION FROM REV B PER DSR #00-587 DM 4/28/00.	MMD 4/20/01
A	ORACLE REVISION CONVERSION DRAWING WAS REVISION 0 UPDATED PER ECO#5151 JH 3/29/01	JWB 9/14/01

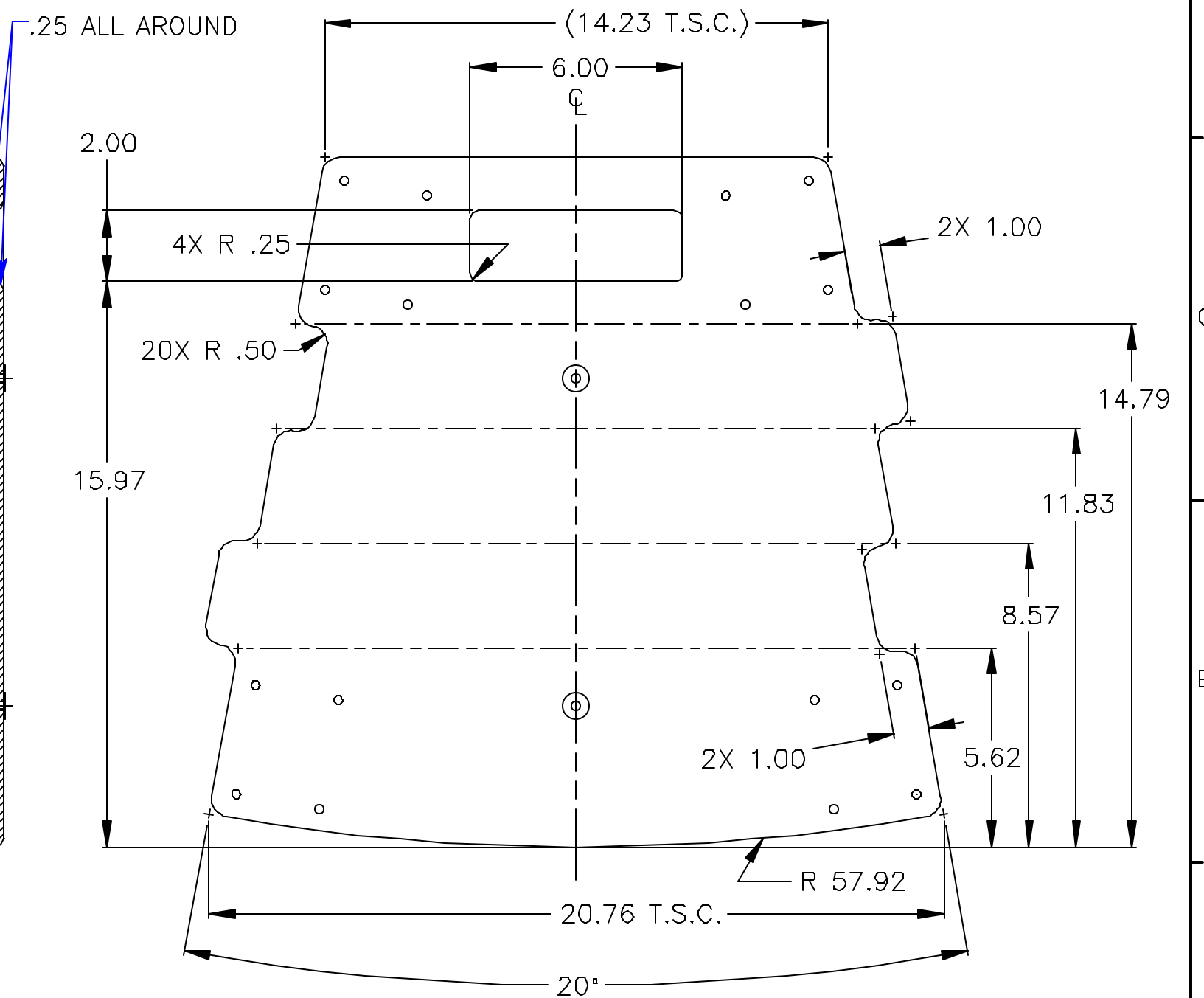
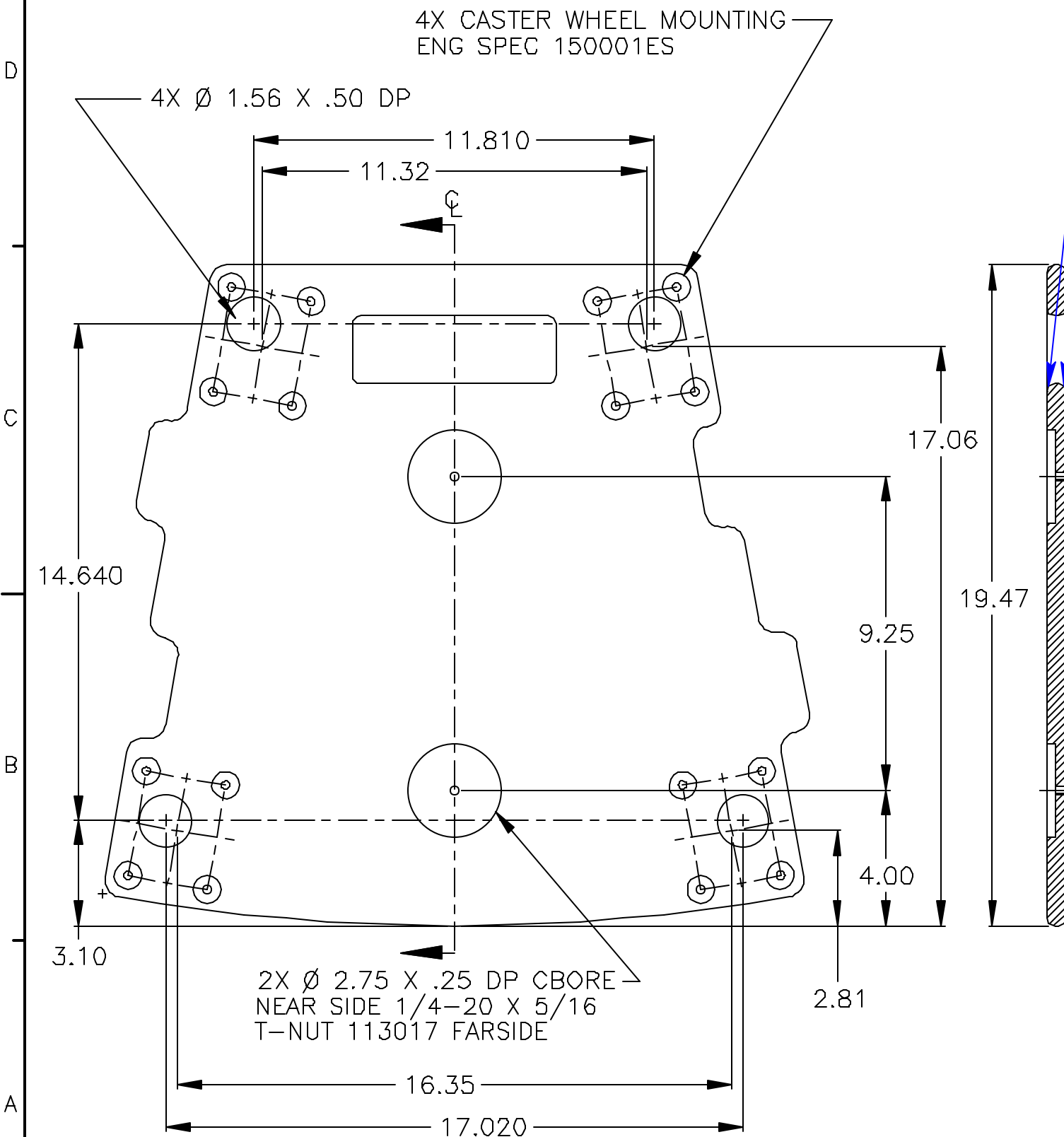

DOCUMENT CONTROL PER SPECIFICATION 4.5.201

THIRD ANGLE PROJECTION 	UNLESS OTHERWISE SPECIFIED: ALL DIMENSIONS ARE IN INCHES TOLERANCE IN INCHES .X ± .1 .XX ± .03 .XXX ± .010 FRACTIONS ± 1/32 ANGLES ± 1/2° (X.XX) = REF DIMS NO TOLERANCE IMPLIED T.S.G.=THEORETICAL SHARP CORNER DIMENSIONS ACROSS CENTERLINES TO BE SYMMETRICAL	STATUS: PRODUCTION		EASTERN ACOUSTIC WORKS ONE MAIN STREET WHITINSVILLE, MA 01588 USA
		APPROVALS DRAWN: JRM CHECKED: MFL DES ENG: JR MFG ENG: CAC	DATE 2/18/98 5/1/00 5/1/00 5/2/00	
THIS DRAWING IS THE PROPERTY OF EAW AND SHALL NOT BE COPIED, REPRODUCED, OR USED AS THE BASIS FOR MANUFACTURE OR SALE OF APPARATUS WITHOUT WRITTEN AUTHORIZATION. DO NOT SCALE DRAWING.			SHEET 1 OF 1 SCALE: 1 TO 4	
			DRAWING NUMBER: 151038 REVISION: A	