

REV	DESCRIPTION	APVD/DATE
A	ORACLE REVISION CONVERSION DRAWING WAS REV 0 PER ECO 5151 SS 6/20/01	ES 6/20/01

**NOTES:**

1. SYMBOL ● INDICATES MOUNTING POINT, 3/8-16 THREADED HOLE (NUT PLATE).
2. SYMBOL ⊙ INDICATES MOUNTING POINT, 3/8-16 THREADED HOLE (PI ANGLE).
3. SYMBOL ⊕ INDICATES CENTER OF BALANCE.
4. WEIGHT APPROX. 57 LBS.
5. SHIPPING WEIGHT APPROX. 64 LBS.

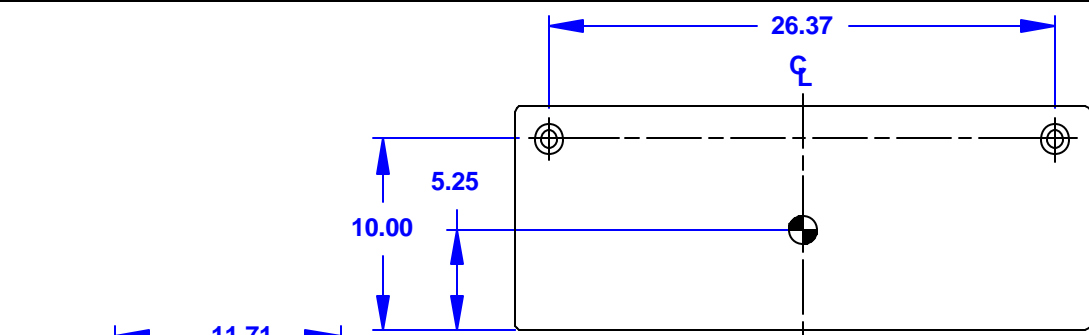

**TOP**

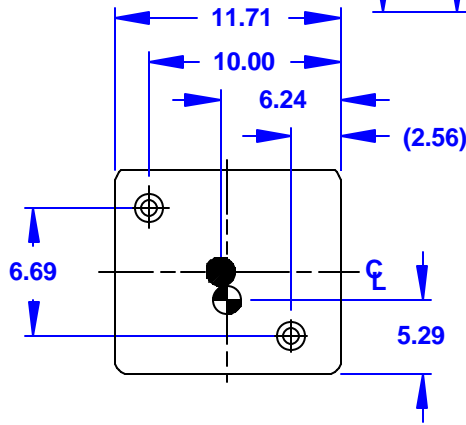

**LEFT SIDE**  
DIMENSIONS APPLY TO BOTH SIDES

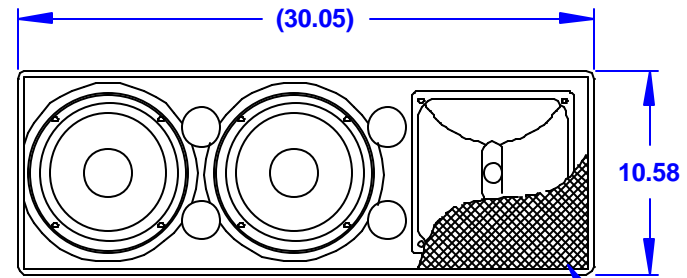

**FRONT**  
GRILLE PARTIALLY SHOWN

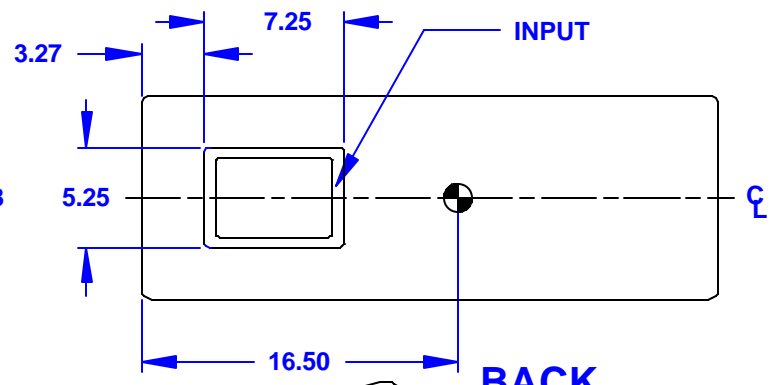

**BACK**

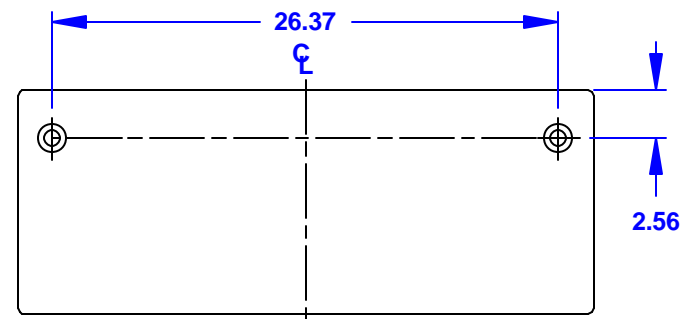

**BOTTOM**

**UB82e**

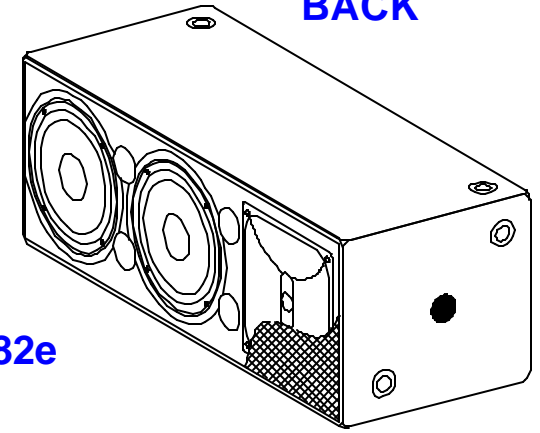

DOCUMENT CONTROL PER SPECIFICATION 4.5.201

THIRD ANGLE PROJECTION

THIS DRAWING IS THE PROPERTY OF EAW AND SHALL NOT BE COPIED, REPRODUCED, OR USED AS THE BASIS FOR MANUFACTURE OR SALE OF APPARATUS WITHOUT WRITTEN AUTHORIZATION. DO NOT SCALE DRAWING.

UNLESS OTHERWISE SPECIFIED; ALL DIMENSIONS ARE IN INCHES

TOLERANCE IN INCHES  
.XX ± .13  
ANGLES ±1°

(X.XX) = REF DIMS  
NO TOLERANCE IMPLIED

T.S.C.—THEORETICAL SHARP CORNER

DIMENSIONS ACROSS CENTERLINES TO BE SYMMETRICAL

STATUS: PRODUCTION	
APPROVALS	DATE
DRAWN: DM	3/8/00
CHECKED: KFH	4/12/00
DES ENG: ZC	4/12/00
MFG ENG: CAC	4/11/00

**EAW** EASTERN ACOUSTIC WORKS  
ONE MAIN STREET  
WHITINSVILLE, MA 01566 USA

TITLE: CABINET/FINISHED/BLACK/  
UB82e  
[MECHANICAL SPECIFICATIONS]

**A** SHEET 1 OF 1 SCALE: 1 TO 10

DRAWING NUMBER: 509004 REVISION: A

