



REV	DESCRIPTION	APVD/DATE
3	REVISED PER ECO #4724 DM 8/18/00.	KFH 9/6/00

- NOTES:**
1. SYMBOL  INDICATES MOUNTING POINT, 3/8-16 THREADED HOLE (PI ANGLE).
 2. SYMBOL  INDICATES CENTER OF BALANCE.
 3. WEIGHT APPRX. 83 LBS.
 4. SHIPPING WEIGHT APPROX. 92 LBS.

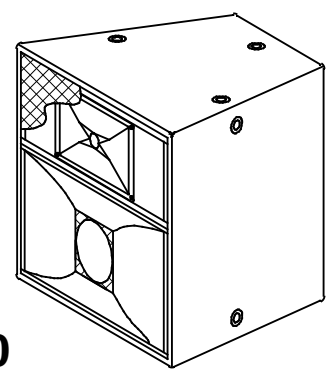
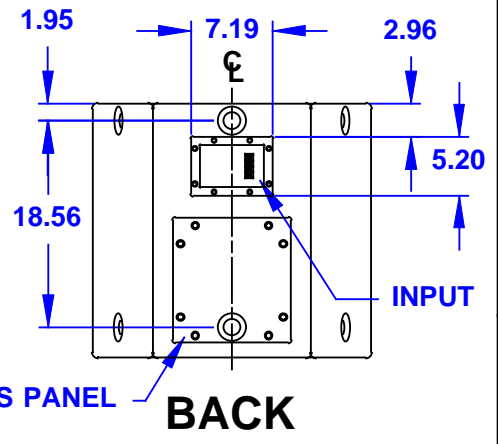
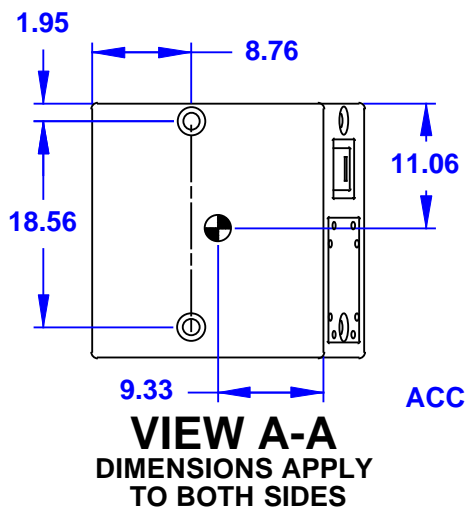
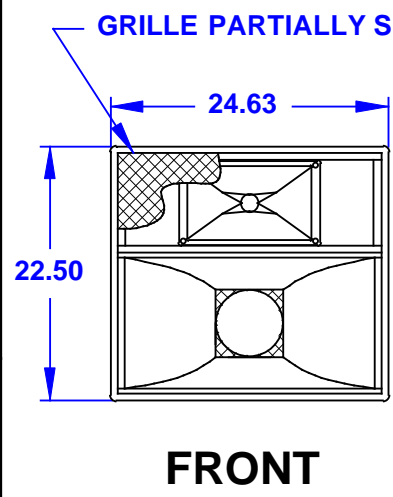
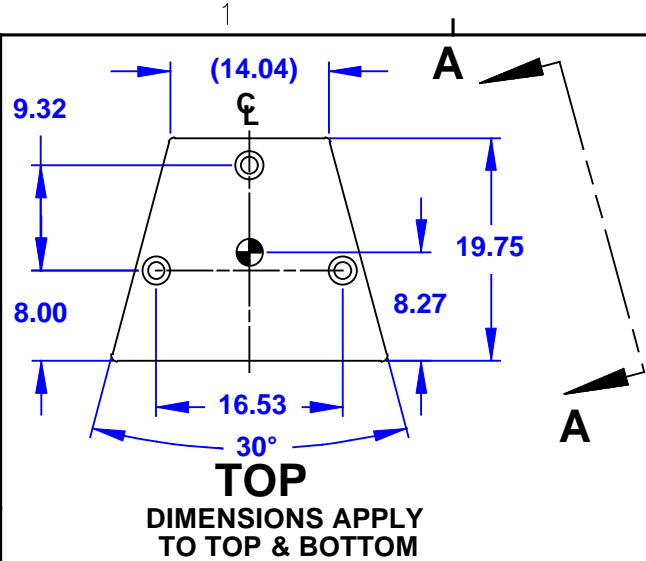

AS490

DOCUMENT CONTROL PER SPECIFICATION 4.5.201

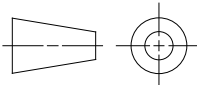
<p>THIRD ANGLE PROJECTION</p>  <p>THIS DRAWING IS THE PROPERTY OF EAW AND SHALL NOT BE COPIED, REPRODUCED, OR USED AS THE BASIS FOR MANUFACTURE OR SALE OF APPARATUS WITHOUT WRITTEN AUTHORIZATION. DO NOT SCALE DRAWING.</p>	<p>UNLESS OTHERWISE SPECIFIED: ALL DIMENSIONS ARE IN INCHES</p> <p>TOLERANCE IN INCHES .XX ± .13 ANGLES ± 1°</p> <p>(X.XX) = REF DIMS NO TOLERANCE IMPLIED</p> <p>T.S.C.=THEORETICAL SHARP CORNER</p> <p>DIMENSIONS ACROSS CENTERLINES TO BE SYMMETRICAL</p>	<p>STATUS: PRODUCTION</p>		<p>EAW EASTERN ACOUSTIC WORKS ONE MAIN STREET WHITINSVILLE, MA 01588 USA</p> <p>TITLE: CABINET/FINISHED/AS490 [MECHANICAL SPECIFICATION]</p>			
		APPROVALS	DATE		<p>A SHEET 1 OF 1</p>		
		DRAWN: PSN	2/27/98			<p>SCALE: 1 TO 16</p>	
		CHECKED: JRM	3/2/98				<p>DRAWING NUMBER: 510633</p>
		DES ENG: ZC	3/2/98				
MFG ENG: KRV	3/2/98						