



# TECHNICAL SPECIFICATIONS AS592ix

## DESCRIPTION

A 3-way full range system housed in a vented rectangular enclosure. Includes a 15-in woofer, a horn-loaded 10-in midrange cone and a 2-in exit compression driver on a 90 x 40 constant directivity horn. Powering mode is biamplified (passive MF/HF crossover).

## APPLICATIONS

The AS592ix adapts Virtual Array Technology to a compact rectangular enclosure engineered for permanent installation. True 3-way design dramatically improves the quality of speech reproduction while the cone-driven midrange horn extends pattern control into the lower octaves. A flexible, powerful installation tool with comprehensive 3/8"-16 mounting/suspension points. Six year warranty.

Applications include:

- Stadium
- Arenas
- Concert Halls
- Dance Clubs
- Large HOW's
- Small HOW's



## DESCRIPTIVE DATA

Part Number	999169
Product Group	I
LF Subsystem & Loading	1x 15-in, Vented
MF Subsystem & Loading	1x 10-in Horn-Loaded Cone
HF Subsystem & Loading	1x 2-in Exit Compression Driver on Constant Directivity Horn
General System Configuration	3-way, Full Range
Powering Configuration(s)	Biamplified (passive MF/HF crossover)
Recommended High-Pass Frequency (24 dB/Octave)	40Hz
Cabinet Type (shape)	Rectangular
Enclosure Materials	Baltic Birch Plywood
Finish	Black Catalyzed Polyurethane
Connectors	4-terminal barrier strip
Suspension Hardware	(12) 3/8"-16 Threaded Mounting/Suspension Points (4 each top and bottom, 2 per side)
Grill	Vinyl Coated Perforated Steel

## NOMINAL DATA

Frequency Response (Hz)	±3 dB	60Hz to 16kHz	
	-10 dB	40Hz	
Axial Sensitivity (dB SPL/1 Watt/1m)	MF/HF	105	
	LF	98	
Impedance (Ohms)	MF/HF	8	
	LF	8	
Power Handling, AES Standard (Watts)	MF/HF	300	
	LF	1000	
Calculated Maximum Output (dB SPL, @ 1m)	MF/HF Peak	135.8	
	LF Peak	134.0	
	MF/HF Long term	129.8	
	LF Long Term	128.0	
Nominal Coverage Angle / -6 dB points (degrees)	Horizontal	90	
	Vertical	40	
Dimensions		inches	millimeters
	Height	22.5	571.5
	Width	41.5	1054.1
Depth	19.75	501.65	
Weights		pounds	kilograms
	Net Weight	172	77.5
	Shipping Weight	176	80.1





# TECHNICAL SPECIFICATIONS AS592ix

## DIMENSIONAL DRAWING

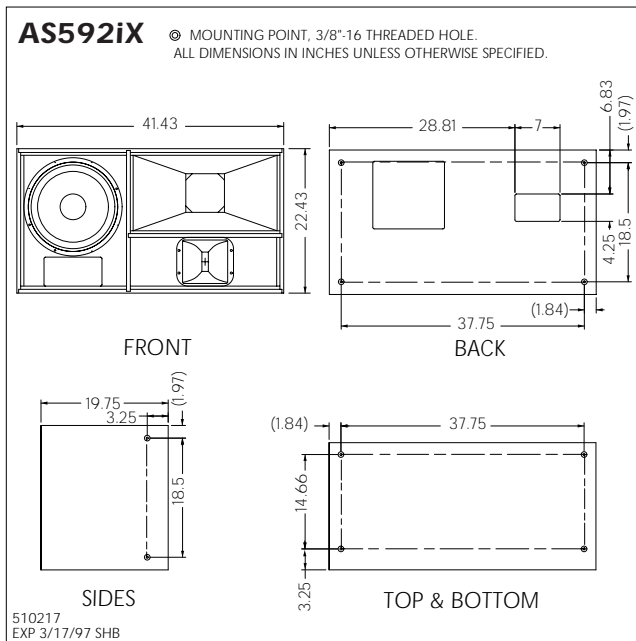

## SERVICE ITEMS

<b>LF: Complete Cone Driver</b>	EAW Part No. 804036
<b>MF: Complete Cone Driver</b>	EAW Part No. 804022
<b>HF: Complete Compression Driver/Tweeter</b>	EAW Part No. 803011
<b>Filter/Crossover Network: Complete Assembly</b>	EAW Part No. 225094

## ARCHITECTURAL SPECIFICATIONS

The 3-way full range loudspeaker systems shall incorporate a 15-in LF transducer, a 10-in MF transducer and a 2-in exit compression driver HF transducer.

The LF driver shall be mounted in a vented enclosure tuned for optimum low frequency response. The MF driver shall be loaded into a constant horizontal coverage horn constructed of 3mm birch plywood reinforced with high density polyurethane foam. The MF horn shall incorporate a phase/displacement plug. The HF driver shall be loaded on a constant directivity horn with a nominal coverage pattern of 90° (h) x 40° (v). An internal passive filter network shall provide fourth order acoustical crossover and system equalization between the mid and high frequency sections.

System frequency response shall vary no more than  $\pm 3$  dB from 60 Hz to 16 kHz measured on axis. The mid/high section shall produce a Sound Pressure Level (SPL) of 105 dB SPL on axis at 1 meter with a power input of 1 Watt, and shall be capable of producing a peak output of 135.8 dB SPL on axis at 1 meter. The low frequency section shall produce a Sound Pressure Level (SPL) of 98 dB SPL on axis at 1 meter with a power input of 1 Watt, and shall be capable of producing a peak output of 134 dB SPL on axis at 1 meter. The mid/high section shall handle 300 Watts of amplifier power (AES Standard) and shall have a nominal impedance of 8 Ohms. The low frequency section shall handle 1000 Watts of amplifier power and shall have a nominal impedance of 8 Ohms.

The loudspeaker enclosure shall be rectangular in shape. It shall be constructed of 15mm thickness void-free cross-grain-laminated Baltic birch plywood and shall employ extensive internal bracing. It shall be finished in black catalyzed polyurethane. Input connectors shall be four-terminal barrier strip. A total of 12x 3/8"-16 threaded mounting/suspension points (4 each top and bottom, 2 per side) shall be provided. The front of the loudspeaker shall be covered with a vinyl coated perforated steel grill.

The 3-way full range loudspeaker shall be the EAW model AS592ix.