

REV	DESCRIPTION	APVD/DATE
2	REVISED PER ECO #4724 DM 8/23/00.	KFH 9/6/00

- NOTES:**
1. SYMBOL ● INDICATES MOUNTING POINT. 3/8-16 THREADED HOLE (NUT PLATE).
  2. SYMBOL ⊙ INDICATES MOUNTING POINT. 3/8-16 THREADED HOLE (PI ANGLE).
  3. SYMBOL ⊕ INDICATES CENTER OF BALANCE.
  4. WEIGHT APPROX. 115 LBS.
  5. SHIPPING WEIGHT APPROX. 120 LBS.

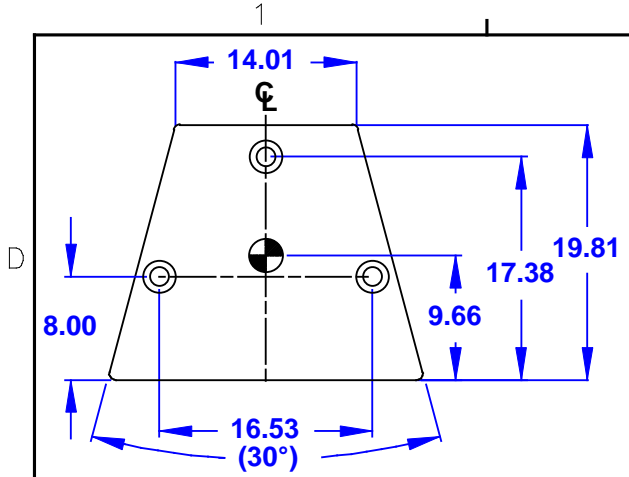

**TOP**

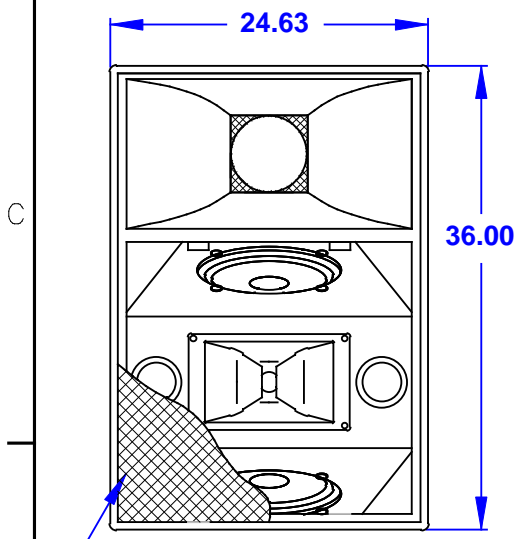

**FRONT**  
GRILLE PARTIALLY SHOWN

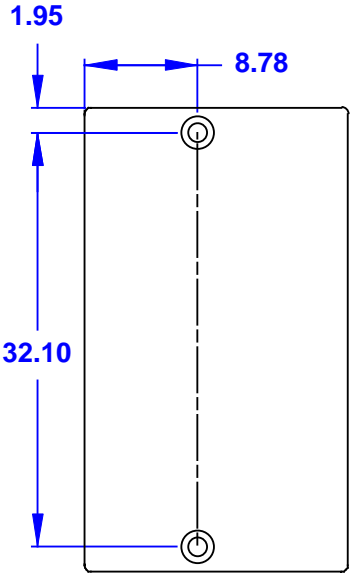

**RIGHT SIDE**  
DIMENSIONS APPLY TO BOTH SIDES

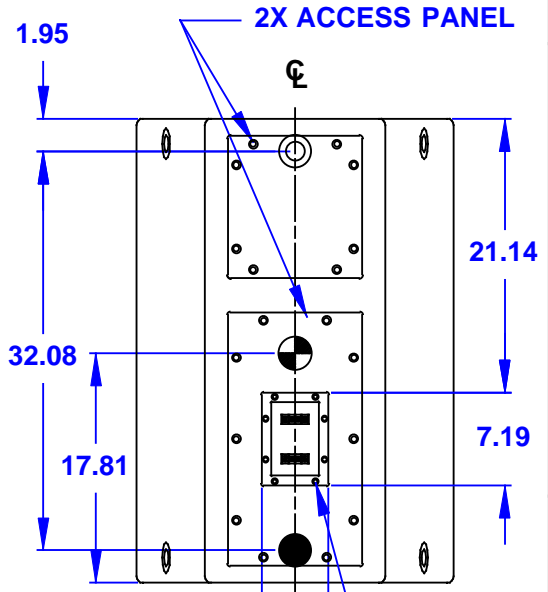

**BACK**

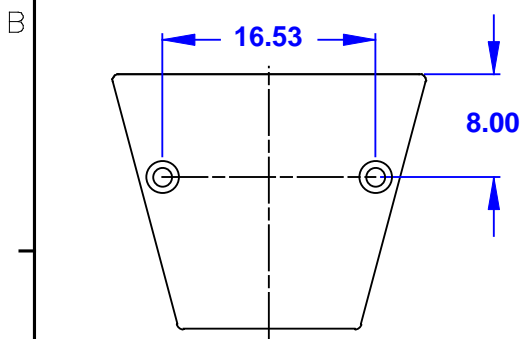

**BOTTOM**

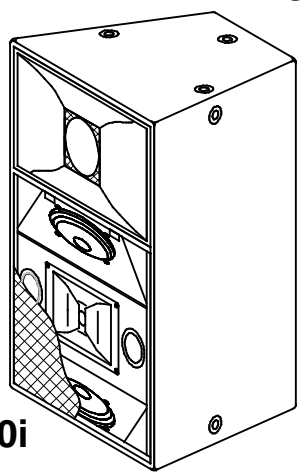

**AS690i**

DOCUMENT CONTROL PER SPECIFICATION 4.5.201

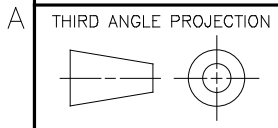

UNLESS OTHERWISE SPECIFIED:  
ALL DIMENSIONS ARE IN INCHES

TOLERANCE IN INCHES  
.XX ± .13  
ANGLES ± 1°

(X.XX) = REF DIMS  
NO TOLERANCE IMPLIED

T.S.C.=THEORETICAL SHARP CORNER

DIMENSIONS ACROSS CENTERLINES  
TO BE SYMMETRICAL

STATUS: <b>PRODUCTION</b>	
APPROVALS	DATE
DRAWN: JRM	2/29/98
CHECKED: N/A	3/2/98
DES ENG: ZC	3/2/98
MFG ENG: KRV	3/2/98

**EAW** EASTERN ACOUSTIC WORKS  
ONE MAIN STREET  
WHITINSVILLE, MA 01588 USA

TITLE:  
CABINET/FINISHED/AS690i  
[MECHANICAL SPECIFICATION]

**A** SHEET 1 OF 1 SCALE: 1 TO 12

DRAWING NUMBER: 510662 REVISION: 2

THIS DRAWING IS THE PROPERTY OF EAW AND SHALL NOT BE COPIED, REPRODUCED, OR USED AS THE BASIS FOR MANUFACTURE OR SALE OF APPARATUS WITHOUT WRITTEN AUTHORIZATION. DO NOT SCALE DRAWING.