

PRODUCT INFORMATION

The CB2590x passive large format 2-way stage screen loudspeaker system fills large theaters with all the high-impact, full-range sound encoded on today's digital soundtracks while reproducing voices clearly and naturally.

The two component system includes a BV253C vented dual 15-in low frequency unit and EAW's breakthrough HK2590 high frequency system – a large format 90° x 40° curved-face horn loading a large diaphragm 2-in exit compression driver.

The subsystems are integrated via an internal passive crossover/filter network. EAW's complex, computer-designed passive filter networks are tightly aligned to the loudspeakers they control and go beyond merely dividing the signal, performing critical equalization functions.

The HK2590's curved-face horn offers several notable advantages over traditional square large format cinema horns. In addition to greatly improved distribution of HF information to the corners of the coverage area and the ability to position left and right channel horns closer to the screen, the curved face minimizes reflections of HF information off the back of the screen which can degrade HF performance. Further, its shortened horn throat minimizes horn throat distortion, eliminating the 700 Hz "honk" that has plagued cinema HF horns. The HF component (compression driver, HF horn, bracket or mounting sled) comes completely pre-assembled from the factory to minimize assembly time.

The BV253C's optimally vented enclosure uses enclosure resonance to increase LF response while limiting driver excursion. This method produces less distortion and minimizes driver strain while producing exceptionally high output levels. Its shallow enclosure dimensions allow convenient placement behind the screen.

The LF enclosure has 3 mounting points to allow optimum front/rear positioning of the HF component. The adjustable mounting sled attaching the HF horn to the LF enclosure can be aimed independently of the LF section in both the horizontal and vertical planes and can be locked once it is positioned.

The two-terminal barrier strip input connector creates a gas-tight connection, minimizing corrosion and maximizing signal transfer. The barrier strip accommodates bare wire, tinned leads or spade lugs. A jumper cable is supplied to extend the signal chain to the HF component. The input connector is located on the side of the enclosure for convenient access in cramped installation areas. HF component connection is made directly on the compression driver.

All components feature a "dead" flat black finish to eliminate the reflection of light through perforated cinema screens.

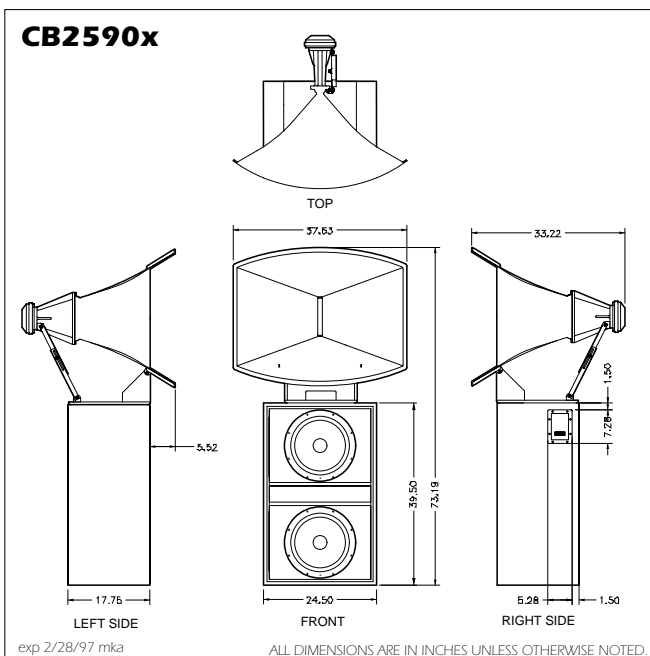

Technical Specifications CB2590x

COMPONENTS & CONSTRUCTION

The CB2590x is a two-way, high output, full range loudspeaker system intended for use in cinema applications. It features dual 15-in low frequency transducers mounted in a compact, vented enclosure and a 2-in exit titanium diaphragm compression driver mounted to a large format 90° x 40° constant directivity horn.

The CB2590x requires no external active electronic crossover. The subsystems are integrated via an internal passive crossover/filter network. EAW's complex, computer-designed passive filter networks are tightly aligned to the loudspeakers they control and go beyond merely dividing the signal, performing critical equalization functions.

The low frequency enclosure is constructed of 3/4-in thick Medium Density Fiberboard with the exception of the baffle which is 15mm void-free, cross-grain-laminated Baltic birch plywood. Extensive internal bracing is employed to minimize panel resonances resulting from the large acoustical energies generated within the enclosures. The enclosure and all external parts are coated with a flat black polyurethane finish.

The high frequency horn is constructed from a specially formulated urethane compound which is non-resonant, lightweight and non-reflective.

Input connector is a 2-terminal barrier strip located on the side of the LF section for convenient access in cramped installation areas. The barrier strip accommodates bare wire, tinned leads or spade lugs. A jumper cable is provided to extend the signal chain to the HF component.

The LF enclosure has 3 mounting points to allow optimum front/rear positioning of the HF component. The adjustable mounting sled attaching the HF horn to the LF enclosure allows the HF horn to be aimed independently of the LF section in both the horizontal and vertical planes and can be locked once it is positioned. The HF component (compression driver, HF horn, bracket or mounting sled) comes completely pre-assembled from the factory to minimize assembly time.

PRELIMINARY INFORMATION

DESCRIPTIVE DATA

Part Number	999527
LF Subsystem & Loading	2 x 15", vented
HF Subsystem & Loading	1 x 2" compression driver on 90x40 horn
Number of Audio Bands	2-way
Type of Audio Bands	Full Range
Powering Mode	Passive, Full range
Controls (switches, knobs)	none
Recommended High-Pass Frequency (24 dB/Octave)	30 Hz
Cabinet Type (shape)	rectangular LF cab with externally mounted HF horn
Enclosure Materials	3/4" MDF with 15mm birch plywood baffle
Finish	Flat Black
Connectors	2 terminal barrier strip

NOMINAL DATA

Frequency Response (Hz)	
±3 db	40 Hz - 18 kHz
Efficiency / Axial Sensitivity (dB SPL/1 Watt/1m)	
Full Range Passive	101
Impedance (Ohm)	
Full Range Passive	4
Power Handling (Watts)	
Full Range Passive AES Standard	600
Calculated Maximum Output (dB SPL)	
Full Range Passive Peak	134.8
Full Range Passive Long Term	128.8
Nominal Coverage Angle / -6 dB points (degrees)	
Horizontal	90
Vertical	40
Recommended Complementary Systems	
Sub	SB184C, SB185C, SB284C
Dimensions	
Height	73.19 in 1859 mm
Width	37.63 in 956 mm
Depth	33.19 in 843 mm
Weights	
Net Weight	203.5 lb 92.6 kg
Shipping Weight	237.5 lb 108.1 kg

