



## APPLICATION

- For large theaters
- Passive 2-way screen channel loudspeaker
- Requires only one amplifier channel and no external crossover

## PRODUCT INFORMATION

The CB2591x passive large format 2-way screen channel loudspeaker system is designed to provide high output, high definition full range frequency response.

The two component system includes a BV253C vented dual 15-in low frequency unit and EAW's HK2591 high frequency system – a large format 90° x 40° horn loading a large diaphragm 2-in exit compression driver.

The LF and HF sections are integrated via an internal passive crossover/filter network. EAW's complex, computer-designed passive filter networks are tightly aligned to the loudspeakers they control and go beyond merely dividing the signal, performing critical equalization functions.

The HK2591's large format HF cinema horn ensures even distribution of HF information over the entire audience area.

The BV253C's optimally vented enclosure uses enclosure resonance to increase LF response while limiting driver excursion. This method produces less distortion and minimizes driver strain while extending LF response to the lowest octaves. Its shallow enclosure dimensions allow convenient placement behind the screen.

The LF section includes a two-terminal barrier strip that accommodates bare wire, tinned leads or spade lugs. The input panel is located on the side of the LF enclosure for convenient access in cramped installation areas. A jumper cable is provided to extend the signal chain to the HF component.

The LF enclosure has 3 mounting points to allow optimum front/rear positioning of the HF component. The adjustable mounting bracket attaching the HF horn to the LF enclosure allows the HF horn to be aimed independently of the LF section in both the horizontal and vertical planes and can be locked once it is positioned.

All components feature a "dead" flat black finish to eliminate the reflection of light through perforated cinema screens.

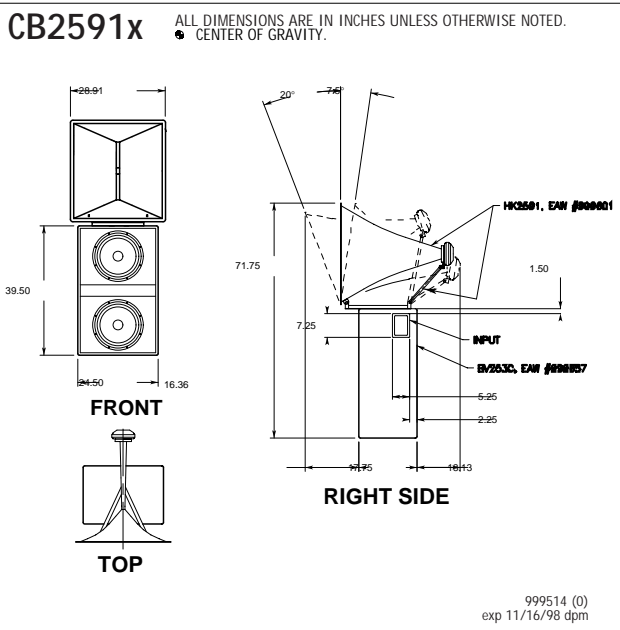

## COMPONENTS & CONSTRUCTION

The CB2591x is a high output, passive, two-way, full range loudspeaker system intended for use in behind screen cinema applications. It features dual 15-in low frequency transducers mounted in a compact, vented enclosure and a 2-in exit titanium diaphragm compression driver mounted to a large format 90° x 40° constant directivity horn.

The CB2591x requires no external active electronic crossover. The HF and LF sections are integrated via an internal passive crossover/filter network. EAW's complex, computer-designed passive filter networks are tightly aligned to the loudspeakers they control and go beyond merely dividing the signal, performing critical equalization functions.

The low frequency enclosure is constructed of 3/4-in thick Medium Density Fiberboard (MDF) and wrapped in flat black vinyl with the exception of the baffle which is 15mm void-free, cross-grain-laminated Baltic birch plywood. Extensive internal bracing is employed to minimize panel resonances resulting from the large acoustical energies generated within the enclosures.

The high frequency horn is constructed from a specially dampened fiberglass which is non-resonant, lightweight and non-reflective.

The LF section includes a two-terminal barrier strip that accommodates bare wire, tinned leads or spade lugs. The input panel is located on the side of the LF enclosure for convenient access in cramped installation areas. A jumper cable is provided to extend the signal chain to the HF component.

The adjustable mounting bracket attaching the HF horn to the LF enclosure can be positioned at one of three mounting points for optimum HF horn placement. It allows the HF horn to be aimed independently of the LF section in both the horizontal and vertical planes and can be locked once it is positioned.

## DESCRIPTIVE DATA

Part Number	999514
LF Subsystem & Loading	2x 15 vented
HF Subsystem & Loading	1x 2" compression driver on 90x40 horn
Number of Audio Bands	2-way
Type of Audio Bands	Full Range
Powering Mode	Passive, Full Range
Recommended High-Pass Frequency (24 dB/Octave)	30 Hz
Cabinet Type (shape)	Rectangular LF cab with externally mounted HF horn
Enclosure Materials	3/4" MDF with 15mm birch plywood baffle
Finish	Flat Black
Connectors	2-terminal barrier strip

## NOMINAL DATA

<b>Frequency Response (1 Watt @ 1m)</b>		
±3 dB	42 Hz - 18 kHz	
<b>Axial Sensitivity (dB SPL, 1 Watt @ 1m)</b>		
Full Range	100	
<b>Impedance (Ohms)</b>		
Full Range	4	
<b>Power Handling, AES Standard (Watts)</b>		
Full Range	500	
<b>Calculated Maximum Output (dB SPL @ 1m)</b>		
Full Range Peak	133.0	
Full Range Long Term	127.0	
<b>Nominal Coverage Angle/-6 dB points (degrees)</b>		
Horizontal	90	
Vertical	40	
<b>Recommended Complementary Systems</b>		
Sub	SB184C, SB185C, SB284C	
<b>Dimensions</b>		
	<b>Inches</b>	<b>Centimeters</b>
Height	77.75	197.5
Width	29.00	73.7
Depth	34.19	86.8
<b>Weights</b>		
	<b>Pounds</b>	<b>Kilograms</b>
Net Weight	182	82.6
Shipping Weight	195	88.5

