



APPLICATION

- For large cinemas
- Bi-amplified 3-way screen channel loudspeaker

PRODUCT INFORMATION

The MC4953B full-range screen channel loudspeaker system brings 3-way design to the largest cinema exhibition spaces. Its passive mid/high bi-amplified design lets it replace existing biamped two-way systems without requiring new electronic crossovers or amplifiers. (Electronic crossover settings may need to be adjusted.)

Three-way design dramatically advances cinema audio quality by improving the naturalness and intelligibility of dialog, eliminating distortion from excessive driver excursion and extending pattern control into the lower octaves.

The MC4953B combines many of EAW's breakthrough technologies including the mathematically correct mid/bass horn with phase/displacement plug, "push/pull" low frequency technology and the "short-throat" high frequency horn.

The three component system includes 2x 15-in woofers in a "push/pull" configuration, 2x horn-loaded 10-in mid frequency cones and a horn-loaded 2-in exit high frequency compression driver.

The "push/pull" configuration of the LF section reduces mechanically induced distortion at high output levels. To move air "forward" (away from the enclosure) half of the woofers push while the other half pull.

The MC4953B's mathematically-correct MF horn with phase plug drastically reduces the horn-throat cancellation distortion that degrades the naturalness and intelligibility of dialog. By dividing the mid/high material between two horn-loaded subsystems, pattern control over the entire frequency range is enhanced.

The MC4953B requires the use of an external active electronic crossover between the LF section and mid/high section which includes an internal passive crossover/filter network. EAW's complex, computer-designed passive filter networks are tightly aligned to the loudspeakers they control and go beyond merely dividing the signal, performing critical equalization functions.

The HF element - an HK294 HF system - features a 2-in exit compression driver loaded with a short-throat 90° x 40° HF horn ensuring even distribution of HF information throughout the auditorium.

Input connectors for the LF and MF sections are two-terminal barrier strips. A "jumper cable" is included to continue the signal chain to the HF section. Bind posts for the HF section are located directly on the compression driver. The input panels are located on the sides of the enclosures for convenient access in cramped installation areas.

All external components feature a "dead" flat black finish to eliminate the reflection of light through perforated cinema screens.

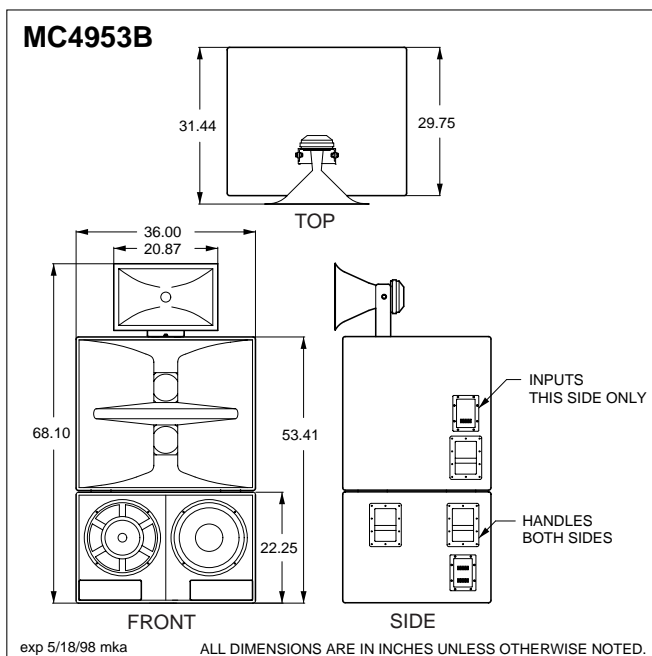

COMPONENTS & CONSTRUCTION

The MC4953B is a biamplified, three-way, very high-output, full range three section loudspeaker system intended for use in behind-screen cinema applications. The optimally vented LF enclosure houses 2x 15-in woofers in a "push/pull" configuration. Dual horn-loaded 10-in midrange drivers are housed in a separate MF enclosure. A 2-in exit high frequency compression driver loaded with a 90° x 40° constant directivity horn is mounted above the MF enclosure.

The system requires the use of an external active electronic crossover between the LF and mid/high sections. The mid/high component includes a internal passive crossover/filter network. EAW's complex, computer-designed passive filter networks are tightly aligned to the loudspeakers they control and go beyond merely dividing the signal, performing critical equalization functions.

Input connectors for the LF and MF sections are two-terminal barrier strips. A "jumper cable" is included to continue the signal chain to the HF section. Bind posts for the HF section are located directly on the compression driver. The input panels are located on the sides of the enclosures for convenient access in cramped installation areas.

The cabinets are constructed of 15mm void-free, 18-ply-to-the-inch, Baltic birch plywood. Extensive internal bracing is provided to minimize panel resonance resulting from the large acoustical energies generated within the enclosure. The enclosure and all external parts are coated with a flat black polyurethane finish.

DESCRIPTIVE DATA

LF Subsystem & Loading	2x 15-in, vented
MF Subsystem & Loading	2x 10-in, horn-loaded
HF Subsystem & Loading	1x 2-in exit compression driver on CD horn
Number of Audio Bands	3-way
Type of Audio Bands	Full Range
Powering Mode	Biampified
System Crossover	Active LF/MF - 300 Hz; Passive MF/HF
Recommended High-Pass Frequency (24 dB/Octave)	30 Hz
Cabinet Type (shape)	Rectangular
Enclosure Materials	15mm Baltic Birch Plywood
Finish	Flat Black
Connectors	2x 2-Terminal Barrier Strips (LF and MF) plus Bind Posts (HF, jumper cable included)

NOMINAL DATA

Frequency Response (1 Watt @1m)		
±3 dB	SMPTE/ISO "X" curve	
	35 Hz - 18 kHz	
Axial Sensitivity (dB SPL, 1 Watt @1m)		
LF	101	
MF/HF	108	
Impedance (Ohms)		
LF	4	
MF/HF	4	
Power Handling, AES Standard (Watts)		
LF	1000	
MF/HF	600	
Calculated Maximum Output (dB SPL @ 1m)		
LF Peak	137.0	
MF/HF Peak	141.8	
LF Long Term	131.0	
MF/HF Long Term	135.8	
Nominal Coverage Angle/-6 dB points (degrees)		
Horizontal	90	
Vertical	40	
Recommended Complementary Systems		
Sub	SB284C	
Dimensions		
	Inches	Centimeters
Height	68.25	173.4
Width	36.0	91.4
Depth	30.0	76.2
Weights		
	Pounds	Kilograms
Net Weight	375	170.0
Shipping Weight	405	183.0

