



APPLICATION

- For large cinemas
- Triamplified 3-way screen channel loudspeaker

PRODUCT INFORMATION

The MC4953 full-range screen channel loudspeaker system brings 3-way design to large cinema exhibition spaces. This system provides high output and must be powered by three amplifier channels (triamplification).

Three-way design dramatically advances cinema audio quality by improving the naturalness and intelligibility of dialog, eliminating distortion from excessive driver excursion and extending pattern control into the lower octaves.

The MC4953 combines many of EAW's breakthrough technologies including the mathematically correct mid/bass horn with phase/displacement plug, "push/pull" low frequency technology and the "short-throat" high frequency horn.

The three component system includes 2x 15-in woofers in a "push/pull" configuration, 2x horn-loaded 10-in mid frequency cones and a horn-loaded 2-in exit high frequency compression driver.

The "push/pull" configuration of the LF section reduces mechanically induced distortion at high output levels. To move air "forward" (away from the enclosure) half of the woofers push while the other half pull.

The MC4953's mathematically-correct MF horn with phase plug drastically reduces the horn-throat cancellation distortion that degrades the naturalness and intelligibility of dialog. By dividing the mid/high material between two horn-loaded subsystems, pattern control over the entire frequency range is enhanced.

The HF element - an HK294 HF system - features a 2-in exit compression driver loaded with a short-throat 90° x 40° HF horn ensuring even distribution of HF information throughout the auditorium.

Each section is provided with its own input connector. The input panels are located on the sides of the enclosures for convenient access in cramped installation areas.

All external components feature a "dead" flat black finish to eliminate the reflection of light through perforated cinema screens.

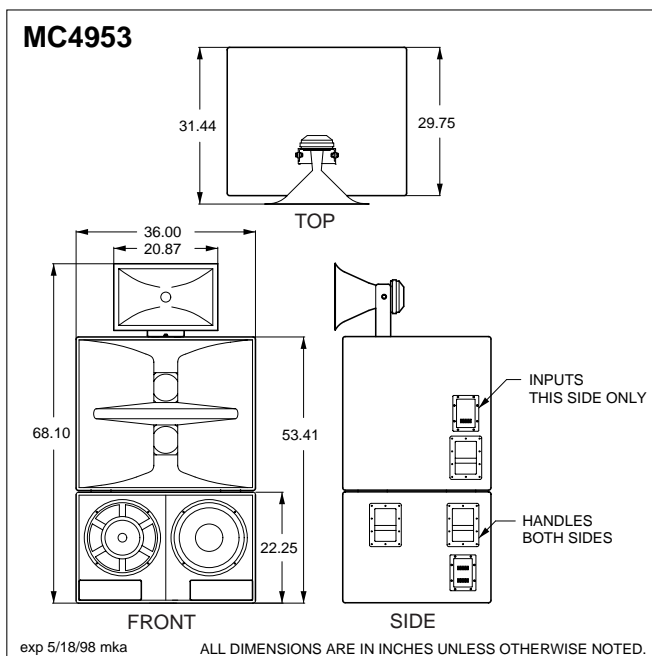

COMPONENTS & CONSTRUCTION

The MC4953 is a triamplified, three-way, very high-output, full range three section loudspeaker system intended for use in behind-screen cinema applications. The optimally vented LF enclosure houses 2x 15-in woofers in a "push/pull" configuration. Dual horn-loaded 10-in midrange drivers are housed in a separate MF enclosure. A 2-in exit high frequency compression driver loaded with a 90° x 40° constant directivity horn is mounted above the MF enclosure.

The system requires the use of a three band external active electronic crossover. Crossover between the LF and MF sections is recommended to be 350 Hz. Crossover between the MF and HF sections is recommended to be 1.8 kHz.

Each section is provided with its own input connector. The input panels are located on the sides of the enclosures for convenient access in cramped installation areas.

The cabinets are constructed of 15mm void-free, 18-ply-to-the-inch, Baltic birch plywood. Extensive internal bracing is provided to minimize panel resonance resulting from the large acoustical energies generated within the enclosure. The enclosure and all external parts are coated with a flat black polyurethane finish.

DESCRIPTIVE DATA

Part Number	999715
LF Subsystem & Loading	2x 15-in, vented
MF Subsystem & Loading	2x 10-in, horn-loaded
HF Subsystem & Loading	1x 2-in exit compression driver on CD horn
Number of Audio Bands	3-way
Type of Audio Bands	Full Range
Powering Mode	Triamplified
System Crossover	Active (LF/MF - 300 Hz; MF/HF - 1.8 kHz)
Recommended High-Pass Frequency (24 dB/Octave)	30 Hz
Cabinet Type (shape)	rectangular
Enclosure Materials	15mm Baltic Birch Plywood
Finish	Flat Black
Connectors	3x 2 terminal barrier strip

NOMINAL DATA

Frequency Response (1 Watt @1m)		
±3 dB	35 Hz - 18 kHz	
Axial Sensitivity (dB SPL, 1 Watt @1m)		
LF	101	
MF	109	
HF	111	
Impedance (Ohms)		
LF	4	
MF	4	
HF	12	
Power Handling, AES Standard (Watts)		
LF	1000	
MF	700	
HF	200	
Calculated Maximum Output (dB SPL @ 1m)		
LF Peak	137.0	
MF Peak	143.5	
HF Peak	140.0	
LF Long Term	131.0	
MF Long Term	137.5	
HF Long Term	134.0	
Nominal Coverage Angle/-6 dB points (degrees)		
Horizontal	90	
Vertical	40	
Recommended Complementary Systems		
Sub	SB284C	
Dimensions		
	Inches	Centimeters
Height	68.25	173.4
Width	36.0	91.4
Depth	30.0	76.2
Weights		
	Pounds	Kilograms
Net Weight	375	170.0
Shipping Weight	405	183.0

