

**MR101L
Extended
Bandwidth
Mid Bass
Reproducer**

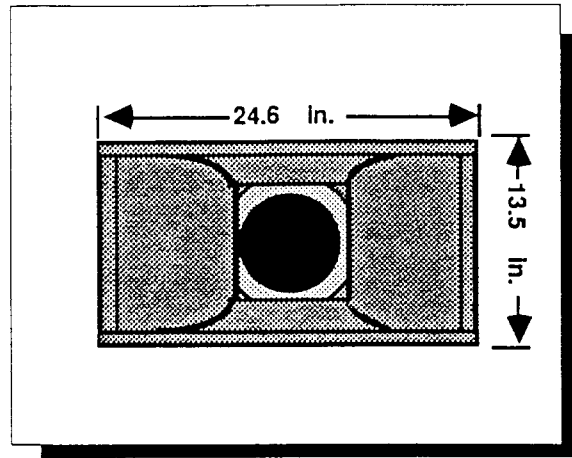

Application

The MR101L is designed for use in high definition music reproduction and reinforcement applications that require high output with 100 degree horizontal coverage. While it was designed for use with the EAW BH500L bass horn and HF590Z high frequency horn, it can be used very effectively to update existing systems. In most instances the addition of the MR101L can significantly improve reliability, power response linearity and low distortion.

Description

The MR101L is a Forsythe designed lower mid range reproducer designed for use in the 250 to 2,000 Hz band where its response is maintained ± 1.5 dB. It features 100 degree horizontal coverage over its entire operating range. The horn design incorporates a center displacement plug which minimizes throat discontinuity and improves off axis performance.

An RCF L10/750 250 mm (10-inch) driver is included which uses a 75mm (3-in) voice coil and massive magnetic structure. The high technology European cone and suspension are optimized for mid range use, eliminating the response resonances above 800 Hz that plague all general purpose 10-inch drivers.

**Architect's &
Engineer's
Specifications**

The loudspeaker system shall be a horn loaded lower mid range type. The horn design shall provide a minimum horizontal coverage angle of 100 degrees and a minimum vertical coverage angle of 40 degrees over its entire operating range. The loudspeaker shall meet the following criteria: Axial frequency response: 250 to 2,000 Hz ± 2 dB. Pressure sensitivity: 108 dB SPL 1w @ 1m. Power capacity: 350 watts in accordance with the AES standards. The cabinet shall be constructed of void-free hardwood plywood. All horn curved surfaces shall be reinforced with polyurethane, and a cast polyurethane center displacement plug shall be provided to maintain power response. The loudspeaker system shall be the Eastern Acoustic Works Forsythe Series MR101L.

**Axial
Frequency
Response**

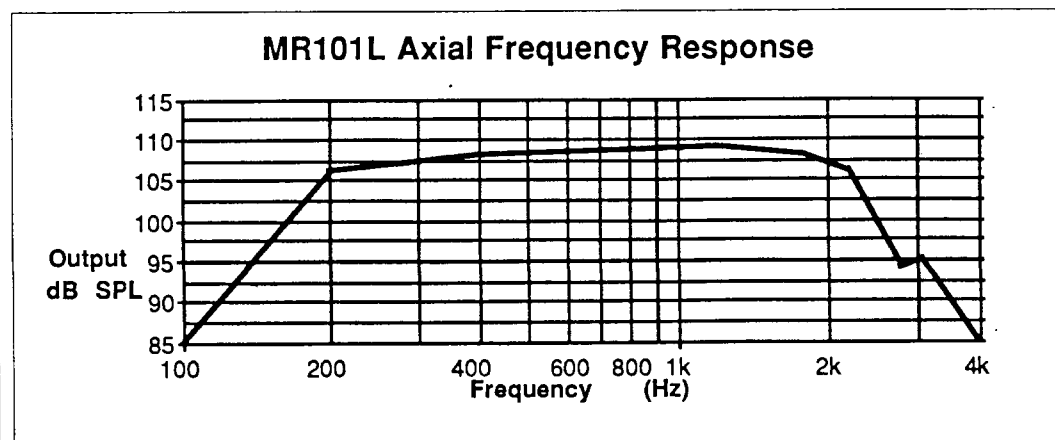

MR102L High Output Mid Bass Reproducer

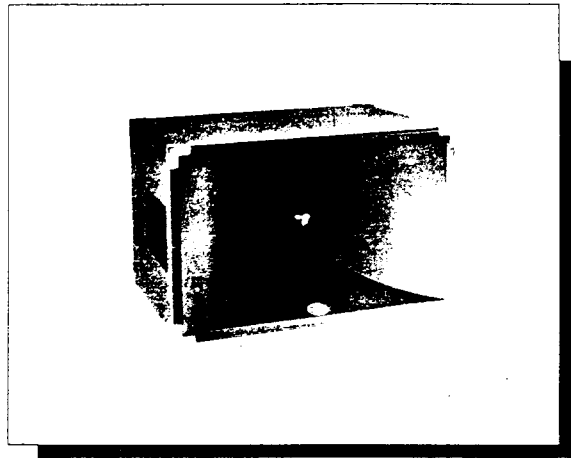

Introduction

Since its introduction in 1978, the MR102 has become the standard for mid bass reproduction in high definition music reproduction systems on five continents. It has been successfully used in symphony halls and the most sophisticated dance clubs. The MR102L is also the mid frequency section of EAW's CS3, KF800, KF400 and KF550 "One Box" systems. Optimum performance is realized when used with the EAW BH800L bass horn and HF590Z high frequency horn. It can also be used effectively to update existing systems.

Description

The MR102L is a Forsythe designed lower mid range reproducer designed for use in the 250 to 1,800 Hz band where its response is maintained ± 2.5 dB. It features 90 degree horizontal coverage over its entire operating range. The horn design incorporates a center displacement plug which minimizes throat discontinuity and improves off axis performance.

An RCF LAB L12/P11W 300 mm (12-inch) driver is included which uses a 100mm (4-in) voice coil and massive magnetic structure. The high technology European cone and suspension are optimized for mid range use, eliminating the response resonances above 800 Hz that plague all general purpose 12-inch drivers. No other horn/driver combination on the market today can match the MR102L's unique combination of constant horizontal coverage, flat frequency response and high acoustic output capabilities.

Architect's & Engineer's Specifications

The loudspeaker system shall be a horn loaded lower mid range type. The horn design shall provide a minimum horizontal coverage angle of 90 degrees and a minimum vertical coverage angle of 40 degrees over its entire operating range. The loudspeaker shall meet the following criteria: Axial frequency response: 250 to 1,800 Hz ± 2.5 dB. Pressure sensitivity: 109 dB SPL 1w, 1m. Power capacity: 350 watts in accordance with the AES standards. The cabinet shall be constructed of void-free hardwood plywood. All horn curved surfaces shall be reinforced with polyurethane, and a cast polyurethane center displacement plug shall be provided to maintain power response. The loudspeaker system shall be the Eastern Acoustic Works Forsythe Series MR102L.

Axial Frequency Response

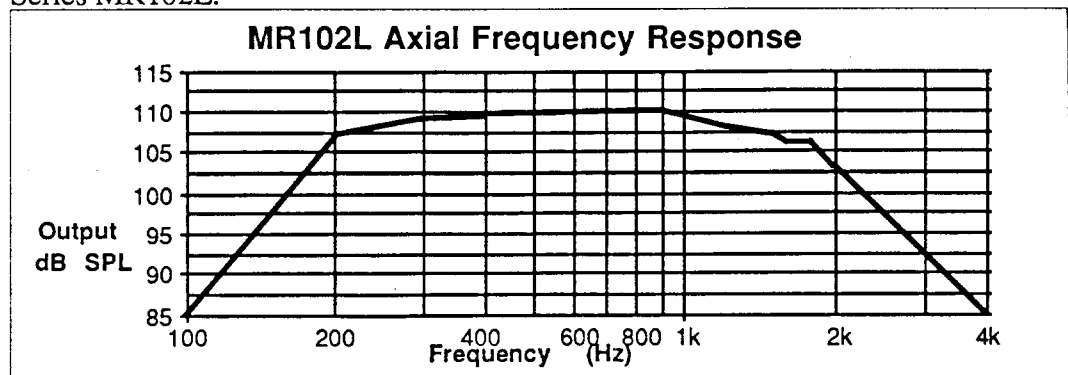

**MR142L
Extended
Low
Frequency
Mid Bass
Reproducer**

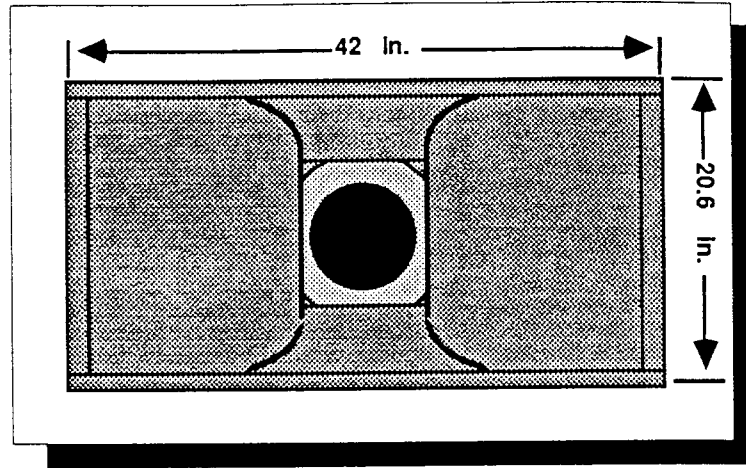

Introduction

The MR142L is a special purpose version of the standard MR102L mid bass reproducer designed for use in applications where response down to 150 Hz is required. The MR142L was originally designed for use with the BH800 and BH440 sub-woofer bass horns, but it is also ideally suited for use with folded bass horns which can not provide flat response above 150 Hz. The MR142L is also recommended for applications where the environment prohibits the location of the mid bass reproducer next to the bass horn. The 150 Hz low frequency limit of the MR142 minimizes the dislocation of source when the mid and bass horns cannot be located next to each other.

Description

The MR142L is a Forsythe designed lower mid range reproducer designed for use in the 150 to 1,800 Hz band where its response is maintained ± 2.5 dB. It features 90 degree horizontal coverage over its entire operating range. The horn design incorporates a center displacement plug which minimizes throat discontinuity and improves off axis performance.

An RCF LAB L12/P11W 300 mm (12-inch) driver is included which uses a 100mm (4-in) voice coil and massive magnetic structure. The high technology European cone and suspension are optimized for mid range use, eliminating the response resonances above 800 Hz that plague all general purpose 12-inch drivers.

**Architect's &
Engineer's
Specifications**

The loudspeaker system shall be a horn loaded lower mid range type. The horn design shall provide a minimum horizontal coverage angle of 90 degrees and a minimum vertical coverage angle of 40 degrees over its entire operating range. The loudspeaker shall meet the following criteria: Axial frequency response: 150 to 1,800 Hz ± 2.5 dB. Pressure sensitivity: 109 dB SPL 1w @ 1m. Power capacity: 350 watts in accordance with the AES standards. The cabinet shall be constructed of void-free hardwood plywood. All horn curved surfaces shall be reinforced with polyurethane, and a cast polyurethane center displacement plug shall be provided to maintain power response. The loudspeaker system shall be the Eastern Acoustic Works Forsythe Series MR142L.

**MR142 Axial
Frequency
Response**

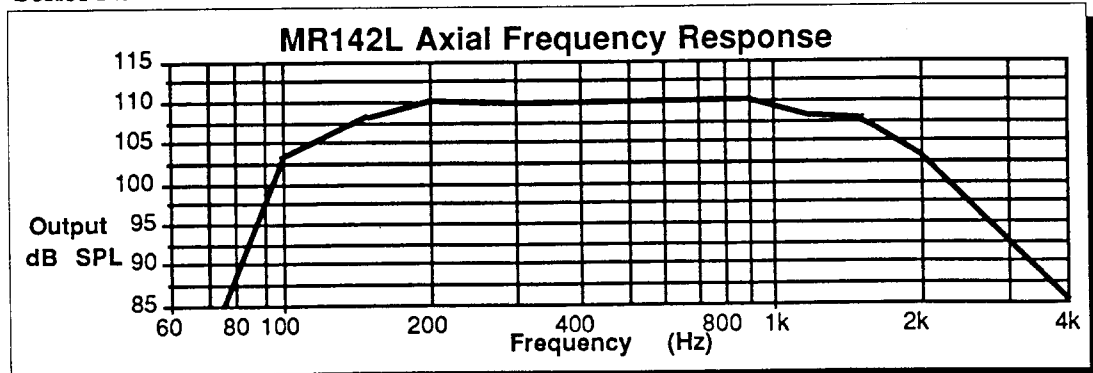

MR Series Specifications

Model	MR101L	MR102L	MR142L
Recommended Operating Range:	250 - 2000 Hz	250 - 1800 Hz	140 - 1800 Hz
High Frequency Limit			
-3 dB:	2,000 Hz	1,750 Hz	1,750 Hz
-6 dB:	2,200 Hz	2,000 Hz	2,000 Hz
Low Frequency Limit			
-3 dB:	250 Hz	220 Hz	140 Hz
-6 dB:	200 Hz	180 Hz	130 Hz
Flare Rate:	180 Hz	175 Hz	130 Hz
Recommended Crossover (minimum 18 dB/octave)			
LF/MF:	250 Hz	250 Hz	140 Hz
MF/HF:	2,000 Hz	1,800 Hz	1,800 Hz
Power Capacity			
Long Term Sine Wave:	150 watts	175 watts	175 watts
AES Standard:	350 watts	400 watts	400
Sensitivity (1w @ 1m)	108 dB SPL	109 dB SPL	109.5 dB SPL
Nominal Efficiency:	20%	28%	30%
Maximum SPL:	132 dB SPL	134 dB SPL	134.5 dB SPL
Coverage Angles			
Horizontal (-6 dB):	100 degrees	90 degrees	90 degrees
Vertical (-6 dB):	50 degrees	40 degrees	40 degrees
Nominal Directivity			
Q:	10	14	14
Di:	10 dB	12 dB	12 dB
Driver Data			
Model:	L10/750	L12/P11W	L12/P11W
Voice Coil:	75 mm (3 in)	100 mm (4 in)	100 mm (4in)
Nominal Impedance:	8 Ω	8Ω	8Ω
Connectors	Dual 1/4-inch phone jacks & banana plugs		
Standard:	Heavy duty Jones type barrier strips,		
Optional:	or blank panel to accept user's terminals		
Construction:	18 plies per inch, cross-grain-laminated, void free birch. All horn surface area voids filled with high damping factor polyurethane foam		
Finish:	Catalyzed black polyurethane chemical coating		
Cabinet Hardware:	Recessed carrying handles, teenuts to mount castors, perforated steel protective grills over drivers.		
Dimensions:	13 1/2 x 24 5/8 x 19 3/4	18 1/2 x 29 3/4 x 24 5/8	20 5/16 x 42 x 29 3/4
Weight:	85 lbs	111 1/4 lbs	125 lbs