

REV	DESCRIPTION	APVD/DATE
0	NEW ISSUE WAS 606130 (0) PER DSR 00-431 MFL 4/12/00	DM 4/26/00
1	ADDED 35.37 DIMENSION PER ECO 4710 MFL 6/16/00	RS 6/20/00
2	CHANGED TITLE ALPHANUMERIC FROM UB42 PER ECO 5313 JRM 7/23/01	RS 7/25/01

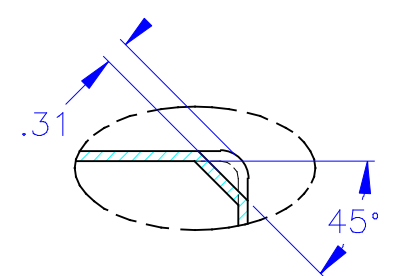

SECTION A-A

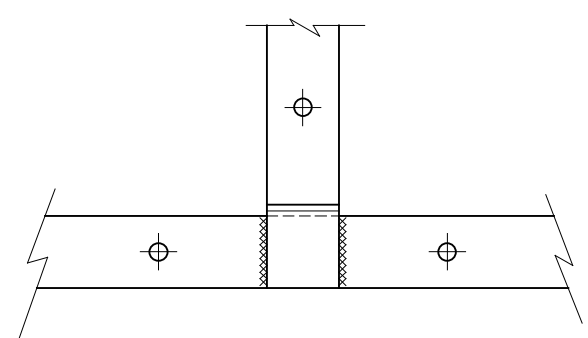

- NOTES:
- PART TO BE FABRICATED TO STANDARD CONFIGURATION SHOWN UNLESS SUPERCEDED BY AUTHORIZED DEVIATION REQUEST.
 - MATERIAL: 10 GA (.134) CRS
 - FINISH: BLACK MATTE POWDERCOAT.
 - REMOVE BURRS AND SHARP EDGES.
 - PARTS TO BE CLEANED AND FREE OF GREASE AND DEBRIS.
 - EAW PART NUMBER AND CURRENT REVISION TO BE STAMPED OR PRINTED IN AREA SHOWN WITH INDELIBLE WHITE INK.
 - TOP OF TONGUE TO BE FLUSH WITH TOP OF U BAR.
 - REFER TO EAW MATERIAL SPECIFICATION 480455 FOR LABELING AND SHIPPING REQUIREMENTS.

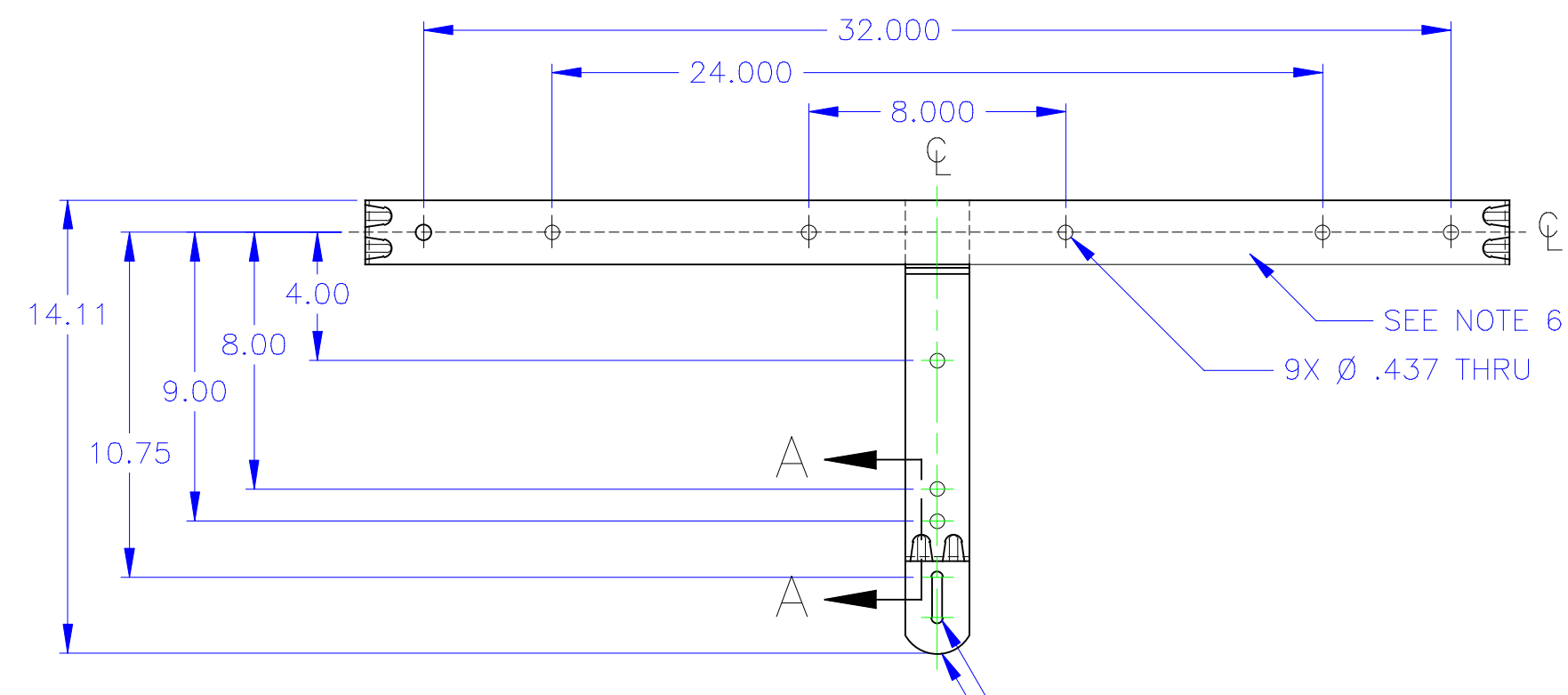
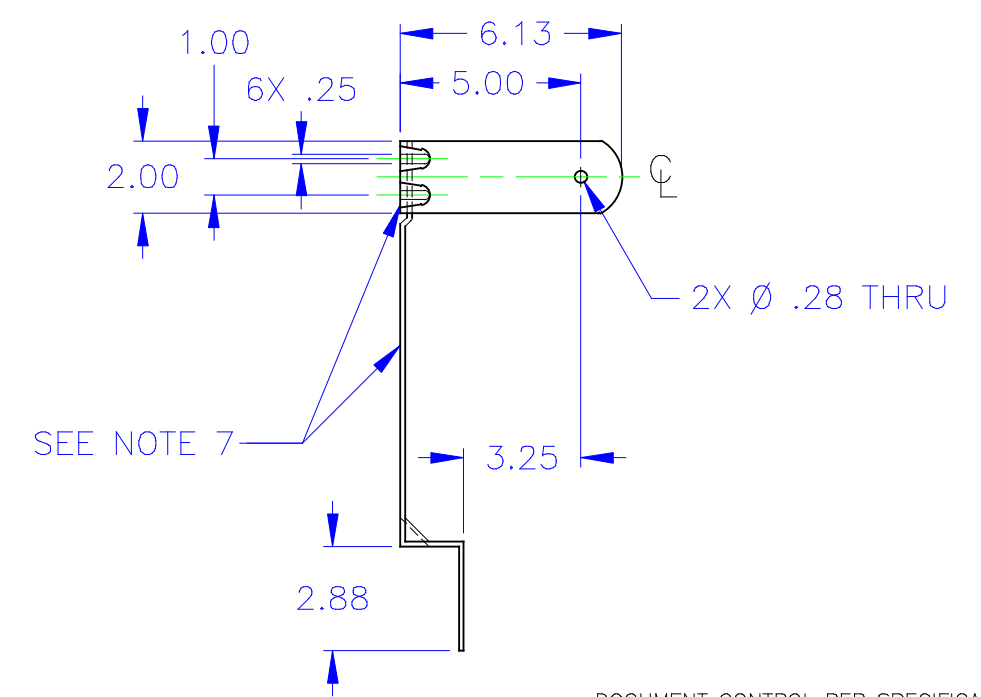
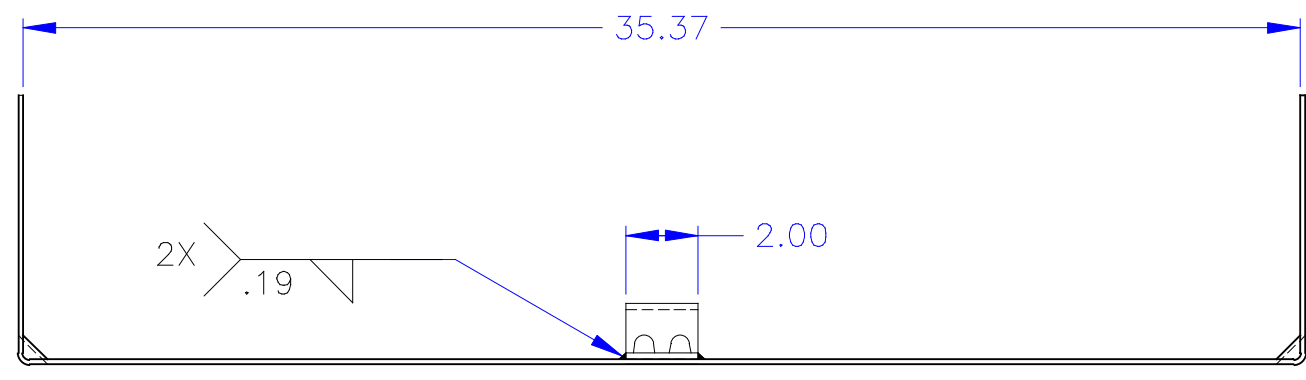

.31 X .125 FULL R SLOT

DOCUMENT CONTROL PER SPECIFICATION 4.5.201

<p>THIRD ANGLE PROJECTION</p> <p>THIS DRAWING IS THE PROPERTY OF EAW AND SHALL NOT BE COPIED, REPRODUCED, OR USED AS THE BASIS FOR MANUFACTURE OR SALE OF APPARATUS WITHOUT WRITTEN AUTHORIZATION. DO NOT SCALE DRAWING.</p>	<p>UNLESS OTHERWISE SPECIFIED: ALL DIMENSIONS ARE IN INCHES</p> <p>TOLERANCE IN INCHES .X ± .1 .XX ± .03 .XXX ± .010 FRACTIONS ± 1/32 ANGLES ± 1/2°</p> <p>(X.XX) = REF DIMS NO TOLERANCE IMPLIED</p> <p>T.S.C.=THEORETICAL SHARP CORNER</p> <p>DIMENSIONS ACROSS CENTERLINES TO BE SYMMETRICAL</p>	STATUS: PRODUCTION		<p>EAW EASTERN ACOUSTIC WORKS ONE MAIN STREET WHITINSVILLE, MA 01588 USA</p> <p>TITLE: BRACKET/CEILING MOUNT/FLUSH /HDUB42CM</p>		
		APPROVALS	DATE		<p>B SHEET 1 OF 1 SCALE: 1 TO 5</p>	
		DRAWN: MFL	4/12/00			<p>DRAWING NUMBER: 606158 REVISION: 2</p>
		CHECKED: DM	4/26/00			
DES ENG: JAR	4/27/00					
MFG ENG: MCB	4/28/00			VELLUM		