

Installation Instructions

UB42 BRACKET

EAW DWG NO 480357 (0)

1. Inventory

Before beginning installation, inventory kit to items listed.

Item	EAW P/N	Qty	Description
1	606130	1	Bracket
2	102017	3	Screw, 1/4-20 x 1 SHCS, Black
3	105061	3	Washer, Neoprene, 1/4 I.D. X 1.0 O.D.
4	105007	3	1/4 Washer, Flat, Black
5	105008	3	1/4 Washer, Lock, Black

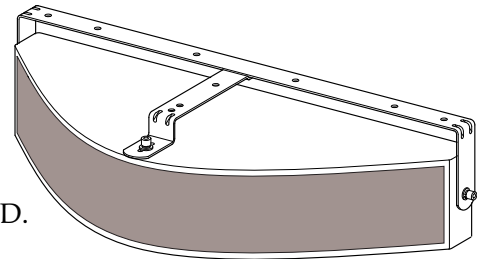

WARNING: Installation should only be done by an experienced technician. Improper installation may cause serious injury. The surface where the bracket/cabinet is to be fastened must have enough structural integrity to support 150 pounds.

2. Mounting the Bracket

Due to various construction methods and materials used today, the hardware for securing the bracket to the mounting surface is not supplied. It is recommended that you consult a building professional for the proper mounting hardware before mounting the bracket.

3. Removing the Shipping Hardware

Remove the three flat head screws from the top and sides of the cabinet using a 5/32 Allen wrench.

4. Hanging the Cabinet

A. Holding the cabinet in position, insert the screw with its lock washer and flat washer through the bracket's right side arm hole then through the neoprene washer and into the cabinet's threaded mounting hole and hand tighten.

B. Repeat step A through the left bracket hole.

C. Repeat step A through the top bracket hole.

D. Tighten the three screws with a 3/16 Allen wrench.

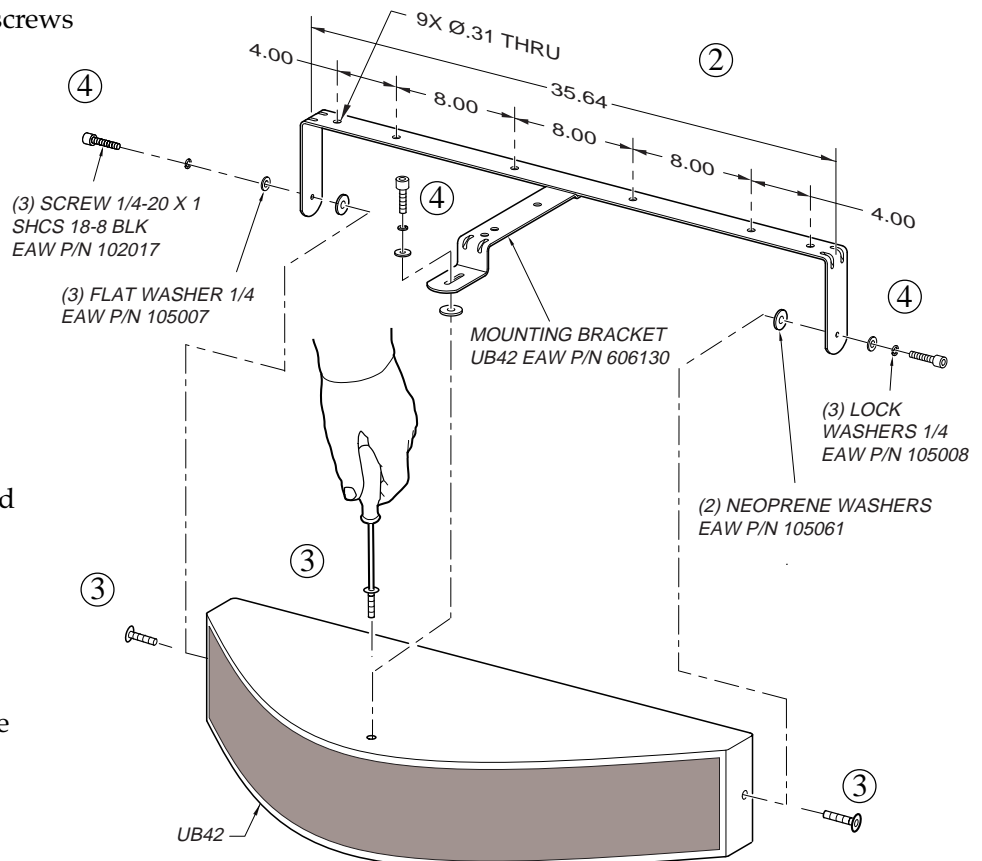

EAW
EASTERN ACOUSTIC WORKS