



PH15

Paging Horn



SPECIFICATIONS

Model PH-15

- Rated Power (rms): 15W
- Impedance: 667 Ω @ 15W, 1.3 k Ω @ 7.5W, 2.7 k Ω @ 3.75W, 5.3 k Ω @ 1.87W, OFF, 8 Ω
- Power Taps @ 100 V: 15W, 7.5W, 3.75W, 1.87W, OFF, 8 Ω
- Power Taps @ 70.7 V: 7.5W, 3.75W, 1.87W, 0.94W, OFF, 8 Ω
- SPL (1W/1m): 108dB
- Max. SPL (15W/1m): 120dB
- Freq. Range (-10dB): 460 Hz - 9K Hz
- Freq. Range (-20dB): 300 Hz - 11K Hz
- Dispersion @ 1 kHz/4 kHz: 110° / 30°
- Water Protection: IEC529 IP66
- Material: High impact ABS
- Color/Finish: Light grey (RAL 7035)
- Dimensions: 8.2 in/208 mm Diameter, 10.7 in/272 mm Length
- Weight: 4.2 lb/1.9 kg
- Mounting: U Type stainless steel bracket

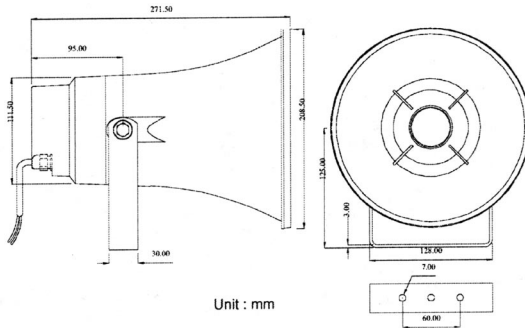

Frequency Response

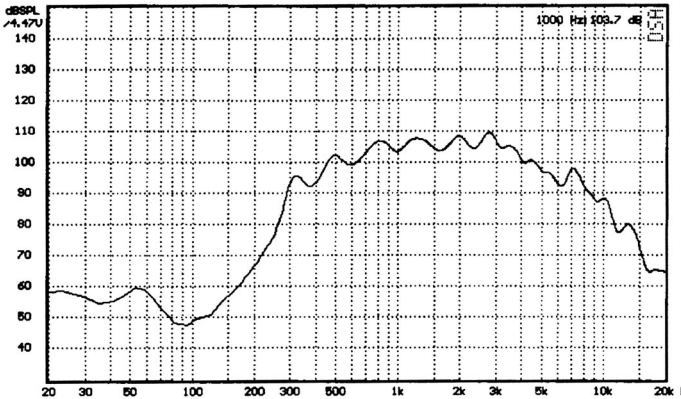



WARNING!

- Installation by qualified personnel only.
- Speakers must be wired in parallel and connected to the correct line terminals of amplifier.
- Ensure that all speakers have the same polarity with respect to each other.
- The sum of the nominal power values of all the speakers connected must not exceed 80% of the amplifier's rated output.
- Do not select another power tap while the speaker is in use!
- No open flame sources, such as lighted candles, should be placed on the apparatus.
- To ensure normal cooling of the PH15, make sure the unit is well ventilated. Maintain a minimum distance of 1.2 in/30 mm around the apparatus for sufficient ventilation.
- Avoid exposure to direct sunlight or proximity to any heat source, dust, or dampness.
- To prevent damage, do not use this speaker with its front pointing upward.

Safety First!

Before connecting and using the equipment, please read this Quick-Start Guide carefully and keep it for future reference.



WARNING! This equipment has been designed to be installed by qualified professionals only! There are many factors to be considered when installing professional sound

reinforcement systems. Some of these factors include mechanical and electrical considerations, as well as acoustic coverage and performance. LOUD Technologies strongly recommends that this equipment be installed only by a professional sound installer or contractor.

CAUTION: To avoid the risk of electric shock, never allow this equipment to be exposed to rain or dampness.

WARRANTY

Warranty: LOUD Technologies Inc. requires its authorized EAW Commercial distributors to abide by the following warranty terms for all EAW Commercial brand products (all dates are from the date of delivery from an Authorized EAW Commercial Distributor to the end user/installation site): Loudspeakers – 5 years; Active Electronics – 5 years; Accessories – 2 years.

What Is Covered: Defects in workmanship and materials and against malfunctions. EAW Commercial distributors must remedy all such defects and malfunctions without charge for parts or labor if the warranty applies. Final determination of warranty coverage lies solely with each authorized EAW Commercial distributor.

What Is Not Covered: This warranty does not extend to damage or malfunctions resulting from, but not limited to, shipment, improper installation, misuse, neglect, abuse, normal wear, accident, or to any product on which the serial number has been modified or removed. Exterior defects in or damage to the exterior appearance are specifically excluded from this warranty. EAW Commercial distributors shall not be liable for incidental or consequential damages resulting from the use of EAW Commercial products. Repairs and/or modifications by other than an Authorized EAW Commercial Distributor automatically voids this warranty.



EAW Commercial | One Main Street | Whitinsville, MA 01588 USA
TEL toll free within US/Canada 888.337.7404 | TEL outside US 425.892.6503 | FAX 425.485.1152
www.eawcommercial.com