



3-WAY FULL-RANGE LOUDSPEAKER 45° x 45°

See *NOTES TABULAR DATA* for details

CONFIGURATION

Subsystem:

<i>Transducer</i>	<i>Loading</i>
LF 4x 12 in cone	Phase Aligned™
MF 1x 2 in exit, 3.5 in compression mid	Horn-loaded
HF 1x 2 in exit, 1.75 in compression driver	Horn-loaded

Operating Mode:

<i>Amplifier Channels</i>	<i>External Signal Processing</i>
Bi-amp (Passive MF/HF) LF, MF/HF	DSP w/EAW Focusing

PERFORMANCE

Operating Range: 55 Hz to 20 kHz

Nominal Beamwidth:

Horz 45°
Vert 45°

Axial Sensitivity (whole space SPL):

LF 103 dB	55 Hz to 530 Hz
MF/HF 113 dB	430 Hz to 20 kHz

Input Impedance (ohms)

	<i>Nominal</i>	<i>Minimum</i>
LF1, LF2 (each)	4	4 @ 210 Hz
LF (total)	2	2 @ 210 Hz
MF/HF	8	6.3 @ 3120 Hz

High Pass Filter

High Pass =>60 Hz, 12 dB/octave Butterworth

Accelerated Life Test

LF1, LF2 (each)	63 V	1000 W @ 4 ohm
LF (total)	63 V	2000 W @ 2 ohm
MF/HF	37 V	175 W @ 8 ohm

Calculated Axial Output Limit (whole space SPL)

	<i>Average</i>	<i>Peak</i>
LF	136 dB	142 dB
MF/HF	135 dB	141 dB

ORDERING DATA

Description	Part Number
EAW QX564 3-Way Full-Range Loudspeaker Black	2035528

Optional Accessories

Adapter Bracket QX BLK [ACC-ABQX]	2036437
Weather Protection Shield QX BLK [ACC-WPSQX]	2036515
U-Bracket Horizontal QX BLK [UBKT-QXH]	2036568

FEATURES

- High output, bi-amplified, 3-way performance
- Premium pattern control
- Ultra-efficient co-axial MF/HF transducer
- Two pairs (horizontal and vertical) of Phase Aligned™ neodymium 12-in woofers
- Installation flexibility

APPLICATIONS

Houses of worship, arenas, outdoor stadiums, performing arts venues, theaters and clubs

DESCRIPTION

The new QX Series is the optimal solution for installed system applications that require precise directivity in a powerful compact form. The QX544 is a 45° x 45° full-range, three-way loudspeaker with a squared, symmetrical, dual-trapezoidal enclosure to provide unlimited array flexibility. A centrally located MF/HF horn and a quartet of 12-inch low frequency transducers team together to ensure that the entire frontal area contributes to horizontal and vertical pattern control capability. Ideal for a wide range of applications including houses of worship, arenas, outdoor stadiums, performing arts venues, theaters and clubs; the premium pattern control and sonic signature of the QX Series is unmatched.

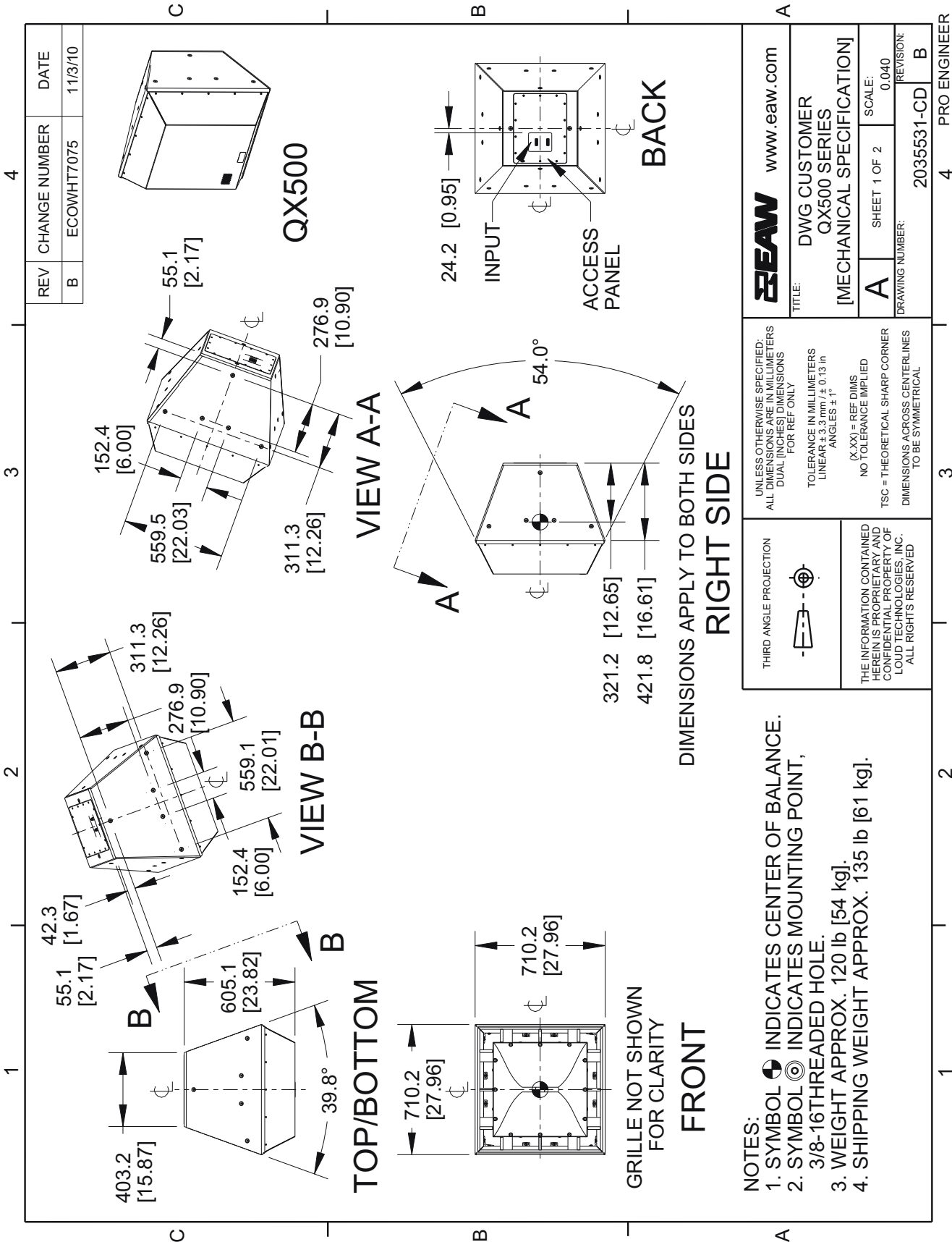

NOTE: This drawing has been reduced. Do not scale.

PERFORMANCE DATA

See *NOTES GRAPHIC DATA* for details

Frequency Response: Processed Multi-Amp

LF = green MF/HF = black Complete = blue

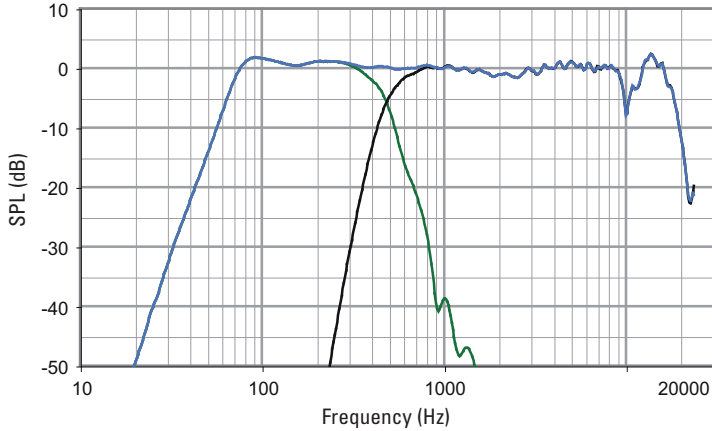

Frequency Response: Unprocessed

LF = green MF/HF = black

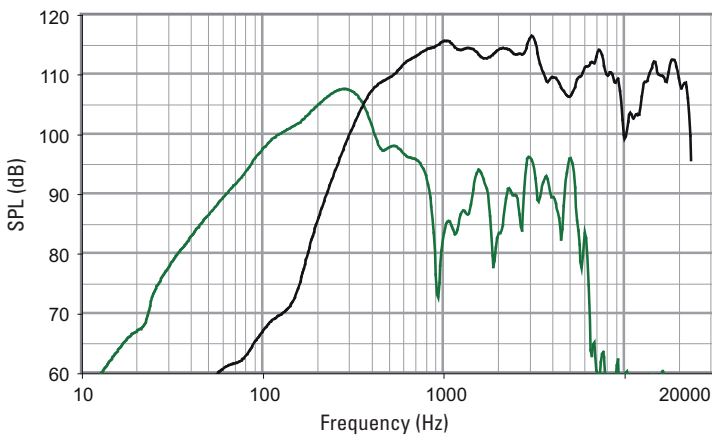

Phase Linearity

Complete = blue

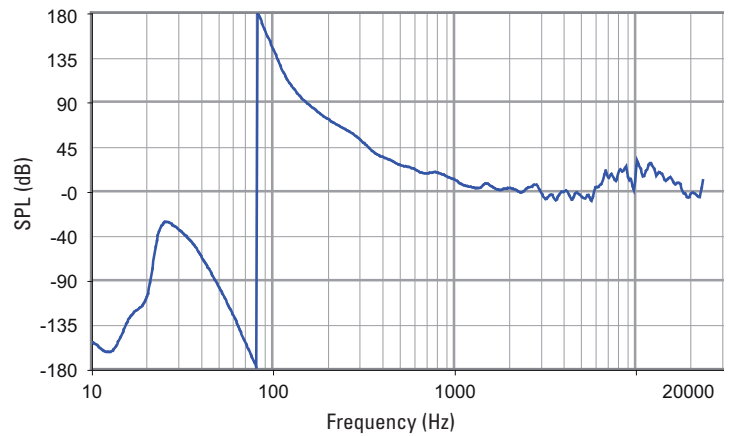

Impedance

LF = green MF/HF = black

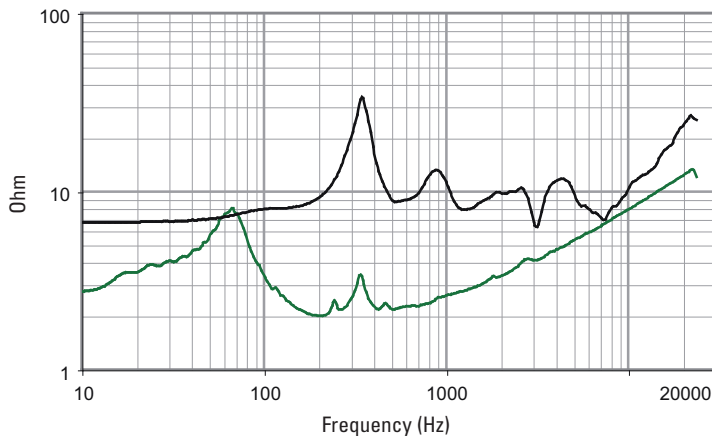

Beamwidth (-6 dB SPL Points)

Horizontal = orange Vertical = black

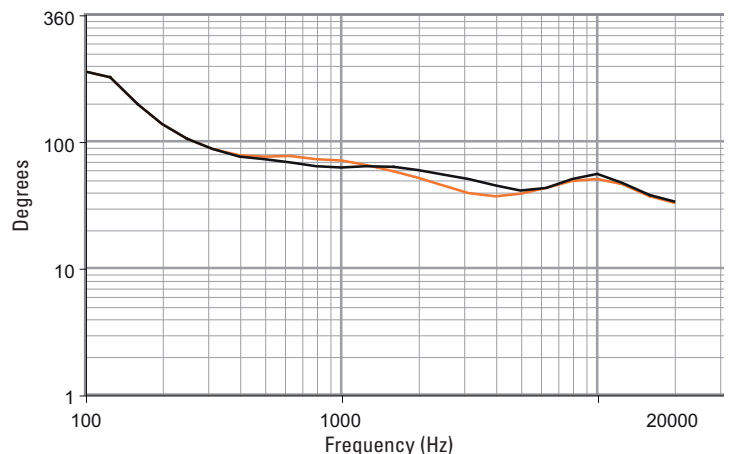

HORIZONTAL POLAR DATA

See *NOTES GRAPHIC DATA* for details

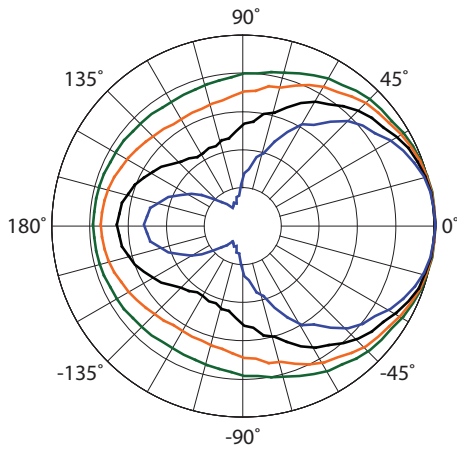

- 100Hz
- 125Hz
- 160Hz
- 200Hz

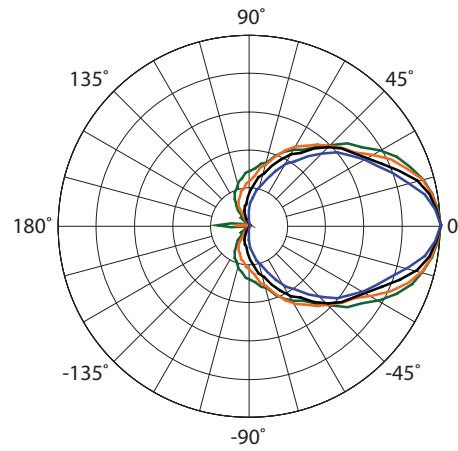

- 1600Hz
- 2000Hz
- 2500Hz
- 3150Hz

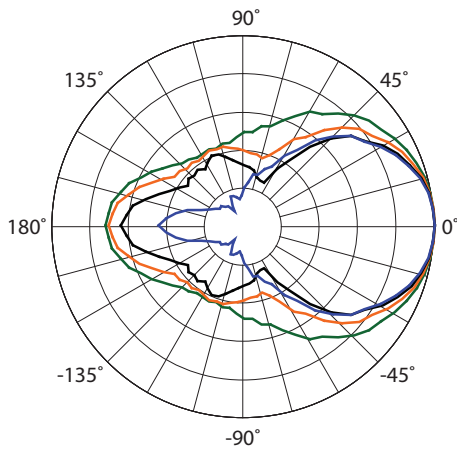

- 250Hz
- 315Hz
- 400Hz
- 500Hz

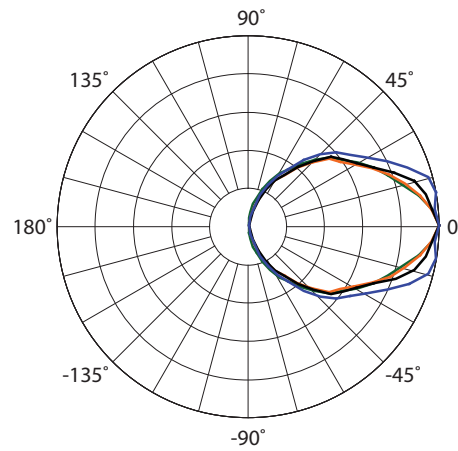

- 4000Hz
- 5000Hz
- 6300Hz
- 8000Hz

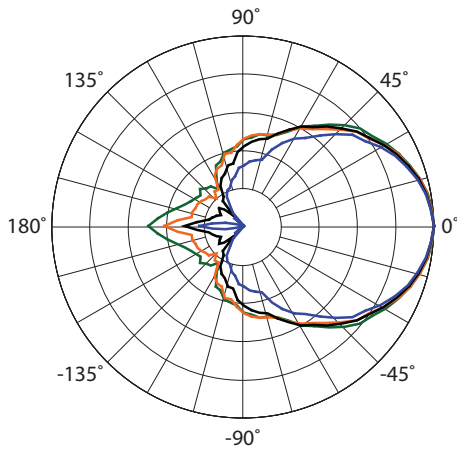

- 630Hz
- 800Hz
- 1000Hz
- 1250Hz

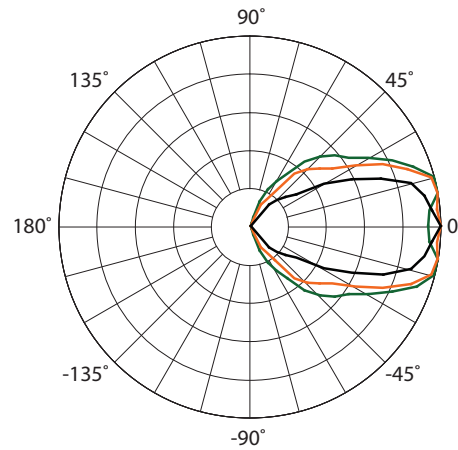

- 10000Hz
- 12500Hz
- 16000Hz

VERTICAL POLAR DATA

See *NOTES GRAPHIC DATA* for details

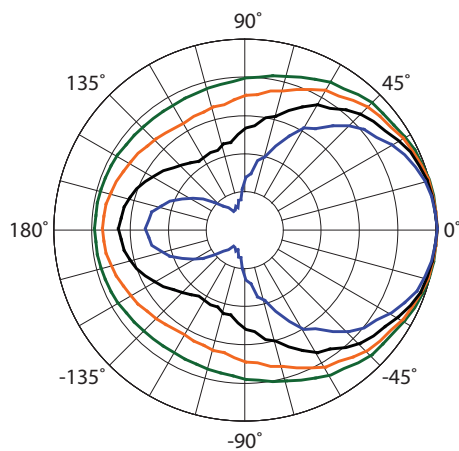

- 100Hz
- 125Hz
- 160Hz
- 200Hz

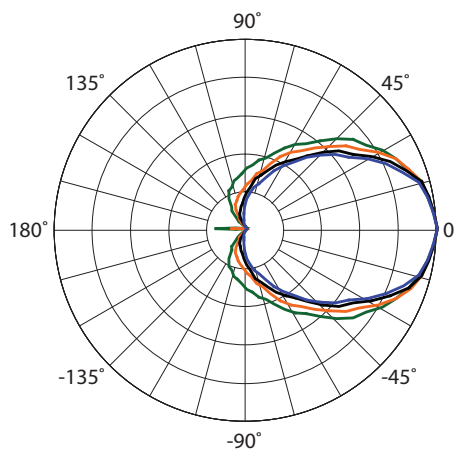

- 1600Hz
- 2000Hz
- 2500Hz
- 3150Hz

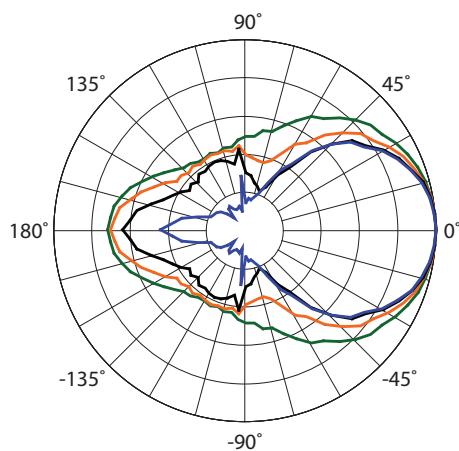

- 250Hz
- 315Hz
- 400Hz
- 500Hz

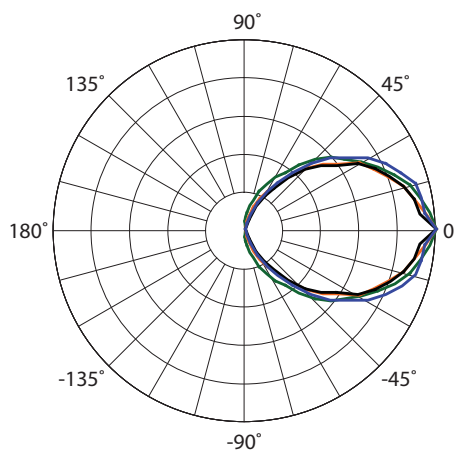

- 4000Hz
- 5000Hz
- 6300Hz
- 8000Hz

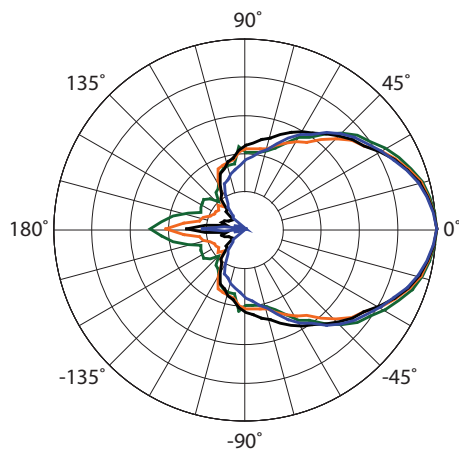

- 630Hz
- 800Hz
- 1000Hz
- 1250Hz

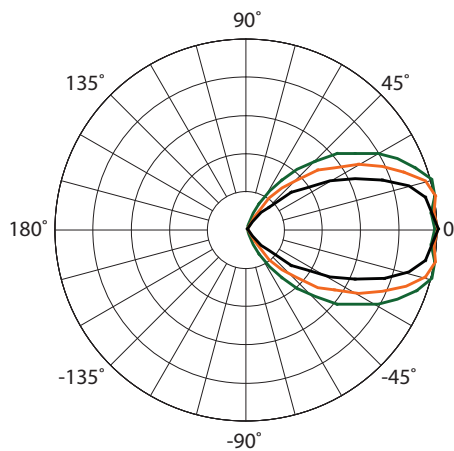

- 10000Hz
- 12500Hz
- 16000Hz

INPUT PANEL

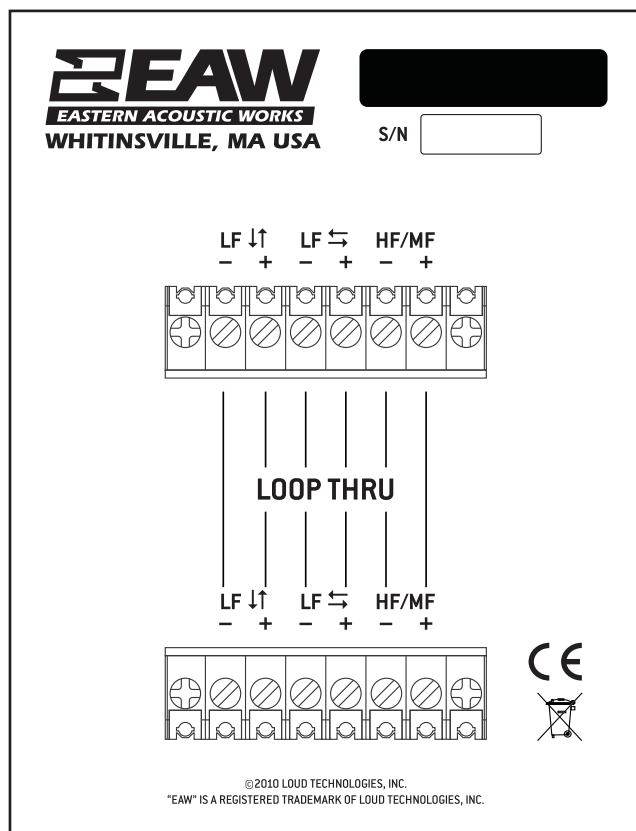

SIGNAL DIAGRAM

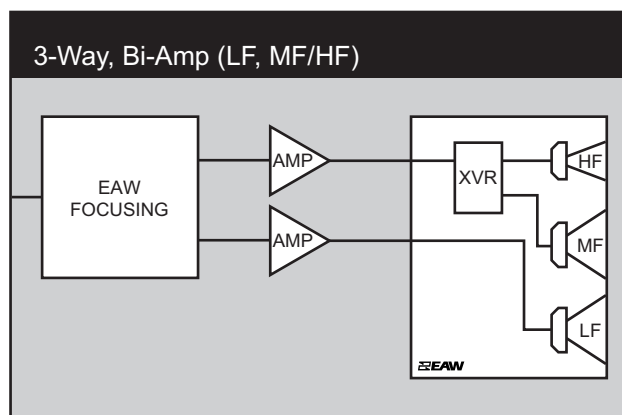

LEGEND

- HPF:** High Pass Filter for crossover –or– Recommended High Pass Filter.
- LPF:** Low Pass Filter for crossover.
- LF/MF/HF:** Low Frequency / Mid Frequency / High Frequency.
- AMP:** User Supplied Power Amplifier –or– Integral Amplifier for NT products.
- XVR:** Passive LPFs, HPFs, and EQ integral to the loudspeaker.
- EAW Focusing:** Digital Signal Processor capable of implementing EAW Focusing.

NOTES

TABULAR DATA

1. **Measurement/Data Processing Systems:** Primary - FChart: proprietary EAW software; Secondary - Brüel & Kjær 2012.
2. **Microphone Systems:** Earthworks M30; Brüel & Kjær 4133
3. **Measurements:** Dual channel FFT; length: 32 768 samples; sample rate: 48 kHz; logarithmic sine wave sweep.
4. **Measurement System Qualification** (includes all uncertainties): SPL: accuracy +/-0.2 dB @ 1 kHz, precision +/-0.5 dB 20 Hz to 20 kHz, resolution 0.05 dB; Frequency: accuracy +/-1 %, precision +/-0.1 Hz, resolution the larger of 1.5 Hz or 1/48 octave; Time: accuracy +/-10.4 µs, precision +/-0.5 µs, resolution 10.4 µs; Angular: accuracy +/-1°, precision +/-0.5°, resolution 0.5°.
5. **Environment:** Measurements time-windowed and processed to eliminate room effects, approximating an anechoic environment. Data processed as anechoic or fractional space, as noted.
6. **Measurement Distance:** 7.46 m. Acoustic responses represent complex summation of the subsystems at 20 m. SPL is referenced to other distances using the Inverse Square Law.
7. **Enclosure Orientation:** For beamwidth and polar specifications, as shown in Mechanical Specification drawing.
8. **Volts:** Measured rms value of the test signal.
9. **Watts:** Per audio industry practice, "loudspeaker watts" are calculated as voltage squared divided by rated nominal impedance. Thus, these are not True Watt units of energy as defined by International Standard.
10. **SPL:** (Sound Pressure Level) Equivalent to the average level of a signal referenced to 0 dB SPL = 20 microPascals.
11. **Subsystem:** This lists the transducer(s) and their acoustic loading for each passband. Sub = Subwoofer, LF = Low Frequency, MF = Mid Frequency, HF = High Frequency.
12. **Operating Mode:** User selectable configurations. Between system elements, a comma (,) = separate amplifier channels; a slash (/) = single amplifier channel. DSP = Digital Signal Processor. IMPORTANT: To achieve the specified performance, the listed external signal processing must be used with EAW-provided settings.
13. **Operating Range:** Range where the processed Frequency Response stays within -10 dB SPL of the power averaged SPL within this range; measured on the geometric axis. Narrow band dips are excepted.
14. **Nominal Beamwidth:** Design angle for the -6 dB SPL points, referenced to 0 dB SPL as the highest level.
15. **Axial Sensitivity:** Power averaged SPL over the Operating Range with an input voltage that would produce 1 W at the nominal impedance; measured with no external processing on the geometric axis, referenced to 1 m.
16. **Nominal Impedance:** Selected 4, 8, or 16 ohm resistance such that the minimum impedance point is no more than 20% below this resistance over the Operating Range.
17. **Accelerated Life Test:** Maximum test input voltage applied with an EIA-426B defined spectrum; measured with recommended signal processing and Recommended Protection Filter.
18. **Calculated Axial Output Limit:** Highest average and peak SPLs possible during the Accelerated Life Test. The Peak SPL represents the 2:1 (6 dB) crest factor of the Life Test signal.
19. **High Pass Filter:** This helps protect the loudspeaker from excessive input signal levels at frequencies below the Operating Range.

GRAPHIC DATA

1. **Resolution:** To remove insignificant fine details, 1/12 octave cepstral smoothing was applied to acoustic frequency responses and 1/3 octave cepstral smoothing was applied to the beamwidth and impedance data. Other graphs are plotted using raw data.
2. **Frequency Responses:** Variation in acoustic output level with frequency for a constant input signal. Processed: normalized to 0 dB SPL. Unprocessed inputs: 2 V (4 ohm nominal impedance), 2.83 V (8 ohm nominal impedance), or 4 V (16 ohm nominal impedance) referenced to a distance of 1 m.
3. **Processor Response:** The variation in output level with frequency for a constant input signal of 0.775 V = 0 dB reference.
4. **Beamwidth:** Average angle for each 1/3 octave frequency band where, starting from the rear of the loudspeaker, the output first reaches -6 dB SPL referenced to 0 dB SPL as the highest level. This method means the output may drop below -6 dB SPL within the beamwidth angle.
5. **Impedance:** Variation in impedance magnitude, in ohms, with frequency without regard to voltage/current phase. This means the impedance values may not be used to calculate True Watts (see 9 above).
6. **Polar Data:** Horizontal and vertical polar responses for each 1/3 octave frequency band 100 Hz to 16 kHz or Operating Range.